

**HAIMER®**  
Quality Wins.

# 3D尋邊器 SENSORS

量測儀器

Measuring Instruments



**HAIMER®**  
Quality Wins.

HAIMER GmbH 公司位於德國伊根豪森市由家族經營的中小企業，創立於 1977 年。專業生產用於 CNC 工具機上各種精密的刀具夾持系統與機器，包含各種 CNC 刀桿、刀桿動平衡機、3D-SENSORS、中心尋找規、高週波感應式刀具燒結機與刀桿、以及其他相關配件。

HAIMER GmbH 公司致力於研發和生產高精度、高品質的產品。同時不斷展現其研發與創新能力，發展出最先進的產品，到目前已是德國最大的 CNC 刀桿生產工廠，並建立了在精密刀桿與精密設備國際性品牌知名度。

HAIMER GmbH 公司全面採用全自動化先進生產設備與技術，以便提供高品質並能使客戶感到物超所值的精密產品。

HAIMER 堅信可以持續以其卓越的技術能力與產品，繼續站穩在市場的位置，並且提供更優質產品資訊與服務，就如 HAIMER 公司的經營哲學：品質勝過一切！  
Quality Wins!



# 3D尋邊器 UNIVERSAL 3D-SENSOR

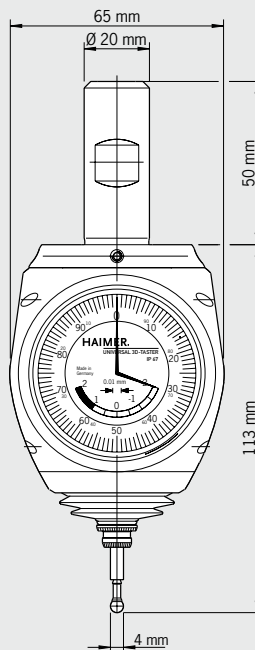
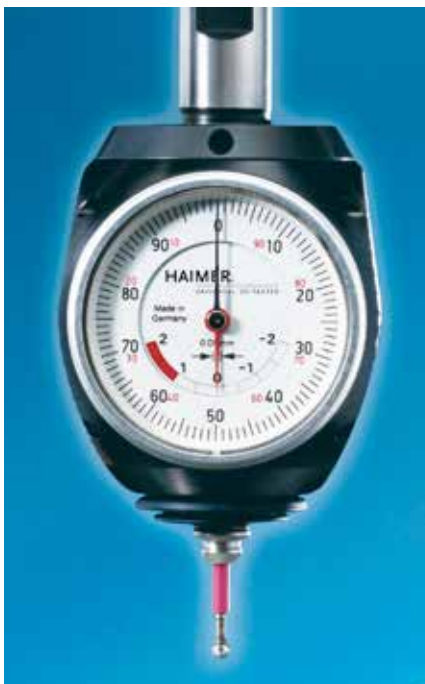

探針 / probe tips

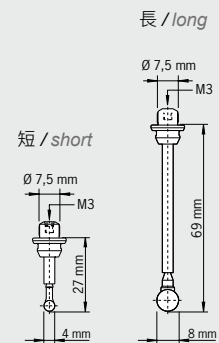

### 3D尋邊器

對於加工中心(包括銑床)和電加工機床而言，3D-Sensor尋邊器是一種高精度、多功能的測量儀器(對於電加工機床，其探針為絕緣感應測尖)。

將3D-Sensor尋邊器固定在機床主軸或電極頭上，主軸中心可以精確地定位在夾具或工件的各邊上。因此，工件零點及長度都可以快速測量及設定。

3D-Sensor尋邊器的優勢在於可以從任意方向(X軸、Y軸或Z軸)接近零件。在量測的過程中，指標始終向同一方向偏移，並始終顯示機床主軸中心與工件邊之間的距離。當指針指示為零時，表示機床主軸軸線與工件邊重合。第一次使用也無需試驗，無需計算，沒有正、負號問題。這大大減少了額外的花費，提高生產效率，並且減輕現場人員的勞動強度。

3D-Sensor尋邊器結構非常堅固，操作方便，長短探針皆適用。同機床刀具一樣，3D-Sensor尋邊器可以裝夾於刀柄上，從而通過換刀或直接安裝到機床主軸上。它的探針無需任何工具就可直接更換。同時為了獲得最大的檢測精度，在組裝過程中，所有尋邊器均經過嚴格檢驗及調整。為了增加安全性，在表的行程末端有紅色安全標記。

- IP 67 防水等級

### Universal 3D-Sensor

The Universal 3D-Sensor is a very precise and versatile measuring instrument for milling and EDM machines (insulated probe). Once clamped into the machine spindle, the run-out (T.I.R) is fully adjustable to Zero. Then, it can be used to bring the spindle axis on the edges of the workpiece. This allows to set zeros and to measure quickly and easily, approachability in any direction (X-, Y-, Z- axis). When the dial gage shows zero, the spindle axis is exactly on the edge of the workpiece.

No calculating of the probe's ball diameter is necessary – just Zero it out! Problems with mathematics or calculations are eliminated. It helps increasing the productivity and accuracy of the operator.

Short and long probes are available. The sensor probes may be changed without any tool, no re-calibration of the unit is needed.

Additional safety, the unit has a large overrun distance in connection with the fully tested preset breaking points giving the sensor long life. All Universal 3D-Sensors are individually tested and adjusted when being assembled in order to achieve a maximum of measuring precision.

- IP 67 waterproof

技術資料 / Technical details		建議使用 HAIMER 刀柄 Recommended HAIMER tool holders	
3D-Sensor 尋邊器包括 ø4mm 短探針 Universal 3D-Sensor with clamping shank ø20 mm including short probe tip ø 4 mm		訂購編號 / Order No.	
精度 / Accuracy	0.01mm	短型SK40側固刀柄 / short chuck SK 40	40.305.20
不包含夾持桿的長度 / Length without clamping shank	113mm	SK50	50.300.20
訂購編號 / Order No.	80.360.00.FHN	BT40	40.500.20
相關配件 / Accessories		BT50	50.500.20
短探針 ø4 mm / Short probe tip ø4 mm		HSK-A 50	A50.000.20
訂購編號 / Order No.	80.362.00	HSK-E 50	E50.000.20
長探針 ø8 mm / Short probe tip ø8 mm		HSK-A 63	A63.000.20
訂購編號 / Order No.	80.363.00	HSK-A 80	A80.000.20
		HSK-A 100	A10.000.20

# 新一代3D-SENSOR尋邊器 3D-SENSOR NEW GENERATION

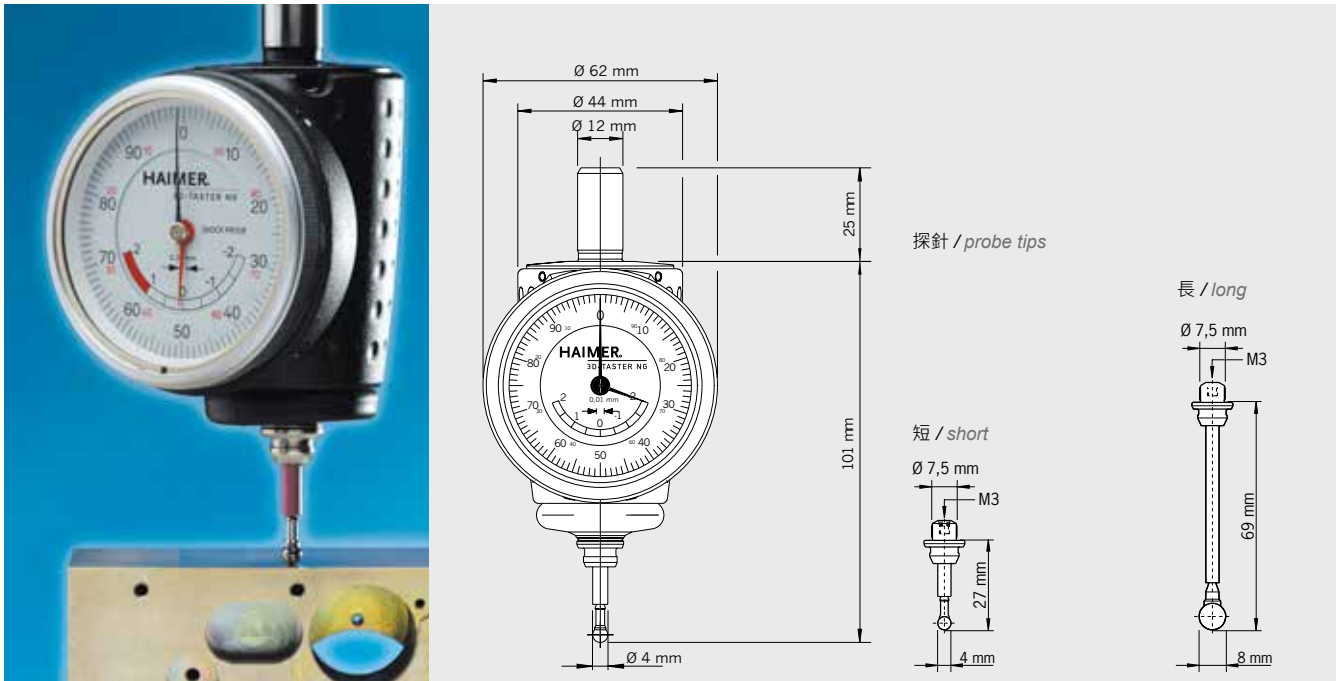

## 新一代3D-Sensor尋邊器

新一代3D-Sensor尋邊器是HAIMER公司在世界範圍認可通用3D-Sensor尋邊器的基礎上更進一步研發的產品。它的顯著特點是改進機械結構和更小更堅固的設計。

### 優點：

- 更加緊湊和易於抓持的殼體，對工作範圍無限制
- 精密顯示主軸位置，使用大於表殼的顯示錶盤(雙指針顯示)
- 0.01mm的超級精度 (當使用原廠HAIMER探針)
- 標識的過行程距離 (安全距離)
- IP 67 防水等級

### 功能：

- 對齊機器主軸到工件或夾具的邊和參考邊 (X軸、Y軸、Z軸)
- 設定0點
- 尋找孔和軸的中心
- 測量長度和深度
- 檢測直線度和平面度
- 對齊工件及虎鉗
- 不需要計算，無正負號錯誤

## 3D-Sensor New Generation

The 3D-Sensor NG is a further development of our worldwide accepted and proven Universal 3D-Sensor. Its distinguishing features are improved mechanics and a new and compact design.

### Advantages:

- Compact and easy to grip casing, no restriction to working area
- Precise display of spindle position with large 1/100 mm dial gauge (2 hands)
- Utmost precision of 0.01 mm (when using original HAIMER probe tips)
- Marked overrun distance (safety distance)
- IP 67 waterproof

### Functions:

- Aligning machine spindles to work piece edges and reference edges (x-, y-, z-axis)
- Set zeros
- Centre borings and shafts
- Measuring lengths and depths
- Checking straightness and levelness of surfaces
- Aligning work pieces and vices
- Quick, without calculations, no mistakes with algebraic signs

### 技術資料 / Technical details

新一代3D-Sensor 尋邊器12 mm 夾柄，包括Ø 4 mm短探針

3D-Sensor NG with clamping shank Ø 12 mm including short probe tip Ø 4 mm

精度 / Accuracy	0.01 mm
不包括夾持柄的長度 / Length without clamping shank	101 mm

訂購編號 / Order No. **80.360.00NG**

### 相關配件 / Accessories

短探針 Ø 4 mm / Short Probe tip Ø 4 mm

訂購編號 / Order No. **80.362.00**

長探針 Ø 8 mm / Long Probe tip Ø 8 mm

訂購編號 / Order No. **80.363.00**



短探針 · 探頭直徑 Ø 4 mm / Short Probe tip Ø 4 mm  
長探針 · 探頭直徑 Ø 8 mm / Long Probe tip Ø 8 mm

## 中心尋找規 CENTRO

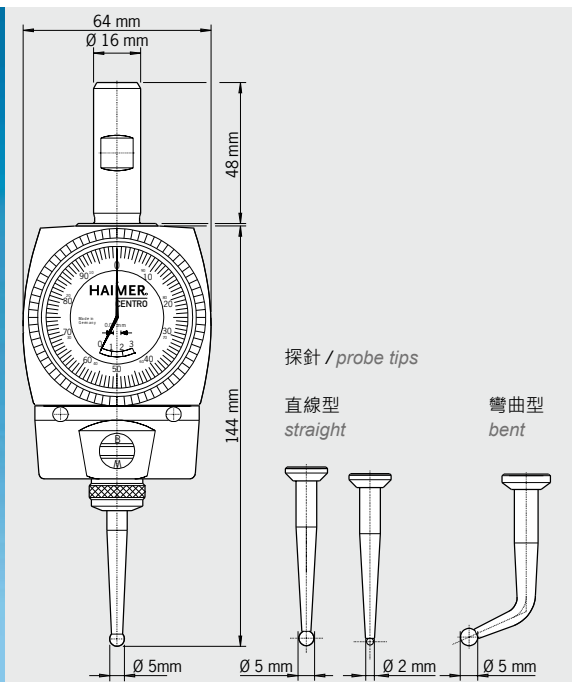

### 中心尋找規

可以快速與精密地將主軸中心與孔對正

將CENTRO中心尋找規夾持在刀桿並裝到機器主軸上，再將探針移動進入要量測的孔內。

調整指針尖端的圓球與工件孔邊輕輕接觸。

### 量錶永遠面對操作者

主軸低速旋轉，指針會與主軸同步旋轉，但是量錶與外殼可以固定，使量錶面對操作者。

### CENTRO中心尋找規確定可以找到主軸與孔同心

慢慢的調整與主軸垂直的兩個軸向，使得CENTRO的指針定下來，這時候機器的主軸就對正孔中心了。

### 更多的優點：

- 檢查主軸與工件的偏擺。
- 主軸誤差可以被自動修正  
>> 使用CENTRO尋找規不需要做任何調整!
- 量錶尺寸大，容易閱讀，可以防止操作人員的失誤。
- 探針可更換，以適應外徑量測或內孔量測。

### Centro

#### Center bores and arbors quick and precise

The Centro is clamped in a tool holder and positioned close the sought axis. The probe tip is adjusted and touches the bore or arbor all the way around.

#### Dial gauge always in field of vision

With low rpm the probe slides along the bore or arbor.

Its movement is transferred to the dial gauge. By using an antenna the Centro does not spin around and stays in field of vision.

#### By using the Centro you find the axis of bores or arbors - reliably

As long as the spindle is out of the center of the bore or arbor the hands of the dial gauge stay in movement. By changing the position of x- and y- axis at the machine you can jibe the axis of the spindle and the work piece.

#### Further advantages:

- Check the axial run-out of the work piece to the spindle
- Compensation of the run-out errors of the spindle and tool holder  
>> No adjustment necessary
- Even in bigger distance the unusual size of the dial gauge is helpful to finish the job
- Replaceable probes

### 技術資料 / Technical details

Centro中心尋找規 探頭直徑Ø 5 mm · 柄徑Ø 16 mm  
Centro with clamping shank Ø 16 mm incl. straight probe tip Ø 5 mm

對心精度 / Centering accuracy	0.003 mm
最高轉速 / Max. rotation speed	150 1/min
孔量測範圍(內徑)/Measuring range interior diameter (drill hole)	3-125 mm
軸量測範圍(外徑)(量測外徑需使用彎探針) Measuring range exterior diameter (shaft, with probe tip bent)	0-125 mm
訂購編號 / Order No.	80.300.00.FHN

### 相關配件 / Accessories

直探針5 mm探頭直徑 / Probe tip straight with diameter of ball 5 mm  
訂購編號 / Order No. 80.301.00

彎探針5 mm探頭直徑/Probe tip bent with diameter of ball 5 mm  
訂購編號 / Order No. 80.302.00

直探針2 mm探頭直徑 · 適合小孔徑使用  
Probe tip straight with diameter of ball 2 mm, for small bores  
訂購編號 / Order No. 80.303.00

### 建議使用HAIMER的精密刀柄

#### Recommended HAIMER tool holders

#### 訂購編號 / Order No.

SK 40	40.300.16
SK 50	50.300.16
BT 40	40.500.16
BT 50	50.500.16
HSK-A 40	A40.000.16
HSK-A 50	A50.000.16
HSK-E 50	E50.000.16
HSK-A 63	A63.000.16
HSK-A 100	A10.000.16

數位式3D-SENSOR尋邊器  
3D-SENSOR DIGITAL

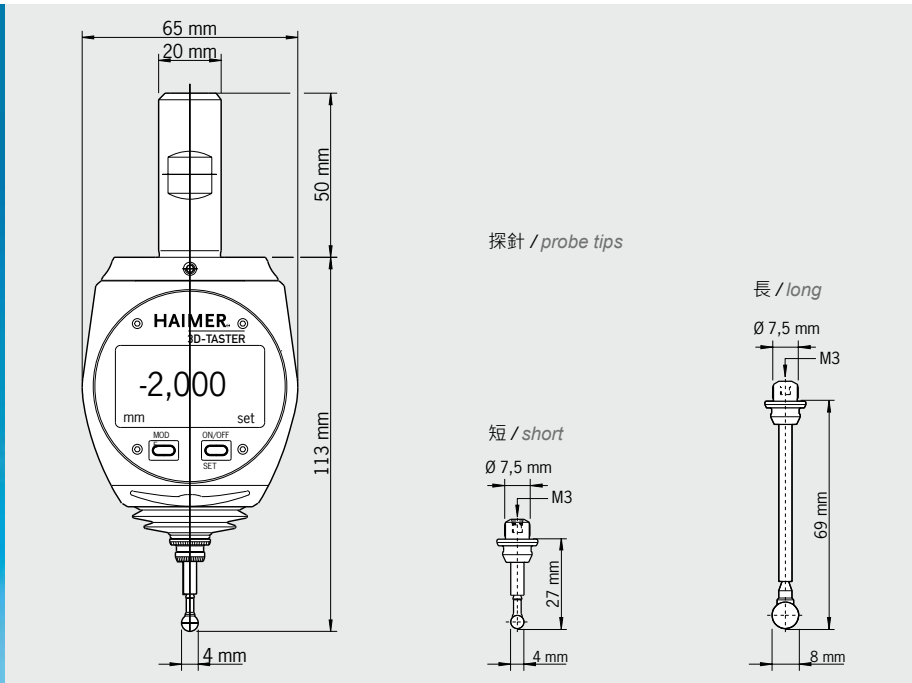

數位式3D-SENSOR尋邊器

高度準確 - 安全操作

數位式3D尋邊器是更為先進高精度的尋邊器。它用於銑床和放電加工機床中工件的找正及工件原點的設置。使得機器主軸或電極可快速定位於參考點，具體的資料將以數位的形式直接在顯示器上顯示。當顯示資料為零時，表示機器主軸中心線與量測點重合，故此無須任何計算，機器座標系就可直接設定。

容易操作

大數字顯示，以0.001毫米的增量測量。

可以很容易地從遠處讀取。(即使安裝在大型加工中心時)

數字顯示器具防水防塵功能 (IP 64)，可存放在機器的刀庫中。

3D-Sensor Digital

Highly accurate – safe handling

The Digital 3D-Sensor is a further development of the time proven mechanical 3D-Sensor. It serves for approaching workpiece edges on milling and EDM machines. The spindle may be positioned quickly and safely on the references edge. The approaching operation can be exactly monitored on the digital display. The zero points can be set without any calculations because the spindle axis is positioned exactly on the approached edge.

Especially practical

The digital display has large numbers that measure in increments of 0.001 mm.

It can be easily read from a long distance (i.e. when mounted on a large machining center). The digital display is water- and dust-proof (IP 64) and can be stored in the tool magazine of the machine.

技術資料 / Technical details	
數位式3D-Sensor尋邊器20 mm 夾柄，包括ø4mm短探針 3D-Sensor Digital with clamping shank Ø 20 mm incl. short probe tip Ø 4 mm	
最小量測單位 / Smallest unit of measure	0.001 mm
重複精度 / Repeatability	0.001 mm
量測精度 / Measuring accuracy	0.005 mm
<b>顯示 / Display</b>	
顯示模式	可切換公英制尺寸
Display mode	May be switched to inch or metric
螢幕尺寸 / Display size	45x23 mm
字元高度 / Height of numbers	8.5 mm
電池壽命 (連續使用)	3000 小時
Service life of battery (continuous operation) approx.	3000 hrs
<b>訂購編號 / Order No. 80.460.00.FHN</b>	
相關配件 / Accessories	
短探針 Ø 4 mm / Short probe tip Ø 4 mm	
<b>訂購編號 / Order No. 80.362.00</b>	
長探針 Ø 8 mm / Long probe tip Ø 8 mm	
<b>訂購編號 / Order No. 80.363.00</b>	

建議使用HAIMER的精密刀柄	
Recommended HAIMER tool holders	
	訂購編號 / Order No.
短型SK40側固刀柄 / short chuck SK 40	<b>40.305.20</b>
SK 50	<b>50.300.20</b>
BT 40	<b>40.500.20</b>
BT 50	<b>50.500.20</b>
HSK-A 50	<b>A50.000.20</b>
HSK-E 50	<b>E50.000.20</b>
HSK-A 63	<b>A63.000.20</b>
HSK-A 80	<b>A80.000.20</b>
HSK-A 100	<b>A10.000.20</b>

# 指針型ZERO MASTER ZERO MASTER

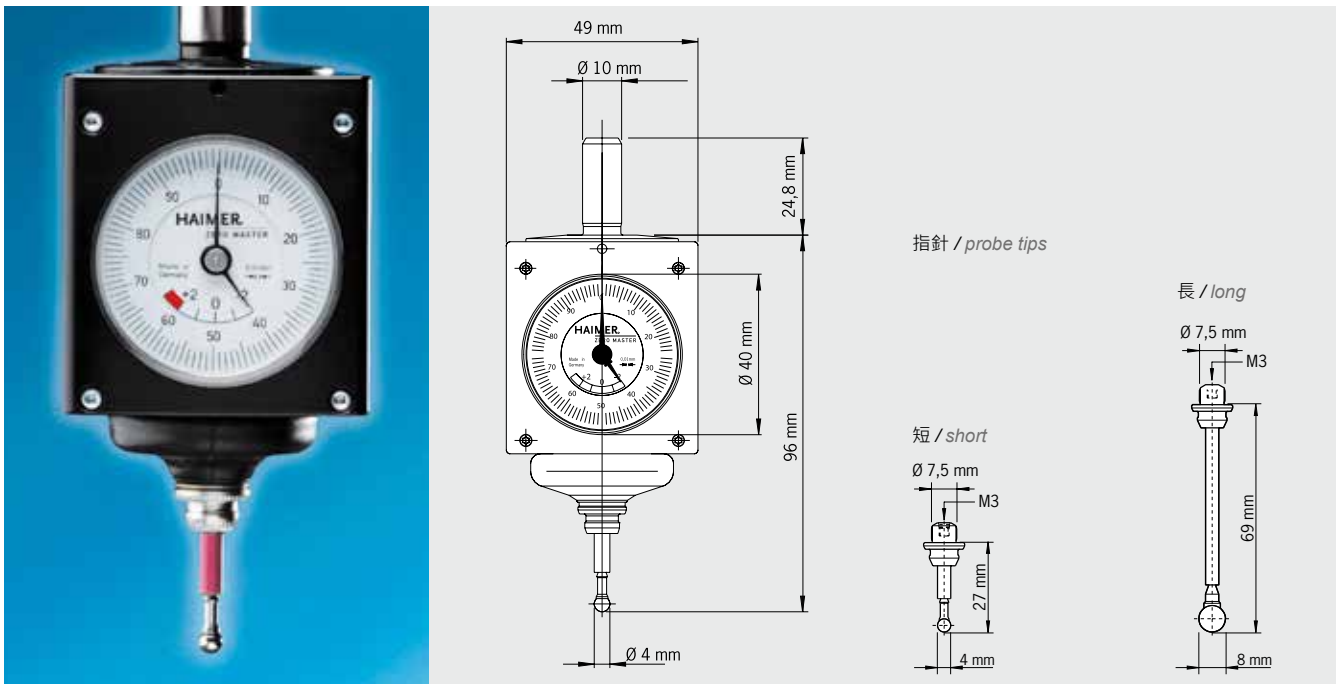

## 指針型Zero Master

### 精巧設計

指針型Zero Master是目前世界上最小的3D-Sensor尋邊器。使用方法、功能及精度和通用3D-Sensor尋邊器一樣。超小型3D-Sensor尋邊器的尺寸適合於非常小的數控，如小型高速銑床等。夾持柄的直徑為10mm，因此它也可以用於ISO(BT)30的主軸或更小的HSK主軸。表殼的長度很短，它的顯示盤採用兩個很小的錶針。長短探針皆可使用。

### 注意：

採用Haimer原廠探針的偏擺小於0.01mm。

– IP 67 防水等級

## Zero Master

### Small but nice

The Zero Master is the smallest 3D-Sensor worldwide. Usage, function and accuracy are equal to the Universal 3D-Sensor. The size of the Zero Master is adapted to small machines. The diameter of the clamping shank is 10mm. Thus it can be also used on machines with ISO 30 or small HSK spindles. The housing is shortened and does not protrude far out of the spindle so even big work pieces can be measured. The Zero Master can be read with a small analog dial gauge.

The Zero Master can be equipped with a short (ball diam. 4 mm) and a long (ball diam. 8 mm) probe tip. The probe tips of course are compatible to all other HAIMER 3D-Sensors.

### Please take note:

The given measuring precision of 0.01 mm only applies if the original HAIMER probe tips are used.

– IP 67 waterproof

### 技術資料 / Technical details

指針型Zero Master尋邊器10mm夾柄，包括ø4mm短探針

Zero Master with clamping shank  $\varnothing$  10 mm including short probe tip  $\varnothing$  4 mm

精度 / Accuracy	0.01 mm
不包括夾持柄的長度 / Length without clamping shank	96 mm

訂購編號 / Order No. **80.960.00**

### 相關配件 / Accessories

短探針  $\varnothing$  4 mm / Short probe tip  $\varnothing$  4 mm

訂購編號 / Order No. **80.362.00**

長探針  $\varnothing$  8 mm / Long probe tip  $\varnothing$  8 mm

訂購編號 / Order No. **80.363.00**



短探針  $\varnothing$  4 mm / Short probe tip  $\varnothing$  4 mm  
長探針  $\varnothing$  8 mm / Long probe tip  $\varnothing$  8 mm

# HAIMER®

Quality Wins.



**JIMMORÉ**  
竣貿國際股份有限公司

© Copyright 竣貿國際股份有限公司 版權所有



總公司：40252台中市南區復興路二段120-2號  
Tel 04-2260-5352 Fax 04-2260-8765  
北部營業處：33548桃園市大溪區埔頂路一段406號  
Tel 03-380-8216 Fax 03-380-3362  
sales@jimmore.com.tw www.jimmore.com.tw

