

**HAIMER®**  
Quality Wins.

刀桿燒結技術

# POWER CLAMP

Shrink fit technology



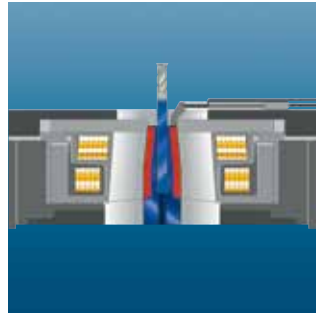

## HAIMER 燒結機 燒結機/Power Clamp

頁數/Page

燒結機的優勢/Power Clamp Advantages	3
線圈的技術/The coil technology	4
接觸式冷卻/The Contact Cooling	5
燒結機系統：基本系列/進階系列/豪華系列/Power Clamp System: Basic Line/Profi Line/Premium Line	6
HAIMER燒結機的投資回收期 Amortisation HAIMER Power Clamp	7
基本型燒結機系列/Power Clamp Basic Line	8 – 9
進階系列燒結機系列：模組化系統 Power Clamp Profi Line: The Modular System	10 – 13
進階系列燒結機系列/PowerClamp Profi Line 經濟型/NG型/Power Clamp Economic/NG	14
進階系列燒結機系列/Power Clamp Profi Line 舒適進階型/NG型/Power Clamp Comfort/NG	15
進階系列燒結機系列/PowerClamp Profi Line NG強力型燒結機/Power Clamp Profi Plus NG NG長度預設定型燒結機/Power Clamp Preset NG	16
豪華系列燒結機系列/Power Clamp Premium Line 豪華型燒結機/NG型/Power Clamp Premium/NG	17
高階系列燒結機系列/Power Clamp Premium Line 高階超級型燒結機/Power Clamp Premium Plus	18
工具車與配件/Carts and Inserts	19
支撐座/Base Holder	20
刀桿支撐架/Chuck Support	21 – 23
ER 燒結刀桿用支撐盤/ChuckSupport for ER Shrink Fit Collets	24
簡單型刀長設定裝置/Easy Set 簡易型刀長設定/Simple Presetting	25
快速長度設定/Quick Set 長度設定/LengthPresetting	26
冷卻轉換套與冷卻轉換套毛坯/Cooling Adapter and Cooling Adapter Blanks	27
迷你型燒結機用加熱冷卻套/MiniShrink Shrink and Cooling Sleeves	28
溫控裝置的冷卻系統/TME Cooling System with Temperature Control	29
燒結刀桿長度調整用支撐彈簧 Tension Springs for Length Presetting for Shrink Fit Chucks	30
斷刀取出裝置/Shrink-Out Device	31
燒結刀桿清潔用毛刷/Shrink Fit Brush	32
燒結刀桿用減徑筒夾/ReductionSleeves for Shrink Fit Chucks	32
廢氣吸收裝置/Auxiliary Fume Extraction Unit	33
13 kW HD 升級線圈/Upgrade Kit 13 kW HD Coil	34
定位環/Stop Discs	35

## HAIMER 燒結機的優點

### POWER CLAMP ADVANTAGES

選擇Haimer燒結系統的五個重要理由

The five most important reasons for HAIMER shrinking technology

1.

適合直徑3~50mm的全碳化鎢刀具與高速鋼刀具

For Ø 3 – 50 mm for solid carbide and HSS tools



2.

紀錄加熱與冷卻時間

- 按下按鍵就可以開始更換刀具
- 採用冷卻水套冷卻加熱的刀桿
- 採用直接接觸的冷卻, 加速冷卻效果
- 均勻冷卻: 刀桿沒有變形的疑慮

Shrinking and cooling in record time

- Tool change at the touch of a button
- Water-cooled cooling bodies
- Concentrated cooling efficiency due to contact cooling
- Even cooling: No material deformation



3.

泛用型的加熱系統與模組化設計

- 適合所有燒結式刀桿
- 適合加長型的刀具

Universal shrinking technology with flexible modular system

- Suitable for all applications
- Also for extremely long tools

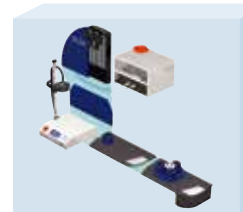

4.

最適工作環境的設計

- 最佳化的設計, 防止燙傷操作人員
- 加熱的刀桿不會接觸到手
- 不會加熱到刀桿的錐度
- 不會加熱到刀具
- 操作容易

Handling adapted to workshop practices

- Optimum protection against burning
- Hot parts need not be taken into the hand
- No heating of the taper
- No heating of the tool
- Easy handling



5.

手動操作確保最低的加熱量

- 刀桿壽命長
- 冷卻時間短
- 精密的能量供應檢測, 最低的能量消耗

Minimal heating due to manual operation

- Long life of the chuck
- Short cooling rate
- Low energy consumption due to precisely metered energy supply





#### 加熱線圈的技术

電磁感應線圈式燒結式刀桿加熱機的核心技术，HAIMER多年來就是感應加熱機的技术領導者，包含有多種的技术與設計專利所設計的加熱線圈，一直保持技术的領先。

#### 標準的加熱線圈

標準加熱線圈已有數年的使用經驗。五種尺寸更換式的定位環，可以適用於3mm到32mm的各種刀具使用。



#### NG新一代加熱線圈

最智慧型的NG新一代加熱線圈，最有彈性與操作的舒適性不需要更換定位環，只需要輕輕的轉一下調整環，就可以適用於不同直徑的刀具。

標準線圈/Standard Coil



#### 感應式加熱系統電源設計

電子系統是燒結系統的第二個重要部分，系統供應了加熱線圈的電源，加熱的頻率與電流必須跟隨刀具的不同做精密的調整與控制，加熱的時間只有數秒鐘的時間，所以必須要有精密的控制才能防止過度加熱，傷害到刀桿。特別設計的能量控制程序可以確保精密的需求，Haimier所提供的輸出範圍是10-20KW。

#### 操作的方便性

Haimier設計的加熱系統有不同的設計，方便不同操作需求與預算。從簡單的系統及最舒適的操作方便性，節省操作訓練時間或是最低的預算都可以購買，也可以讓投資在最短的時間內回收。

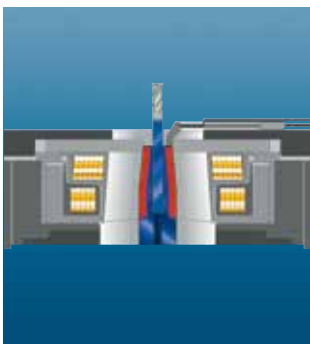

NG新一代線圈/NG coil

#### Coil technology

The induction coil is the core of inductive shrink fit technology. HAIMER has been the leading developer of inductive shrink fit technology for tool holders for years. A number of patents, predominantly in the field of induction coils, is the visible proof of our innovation and advancement.

#### The standard coil

The standard coils have been proven for years with interchangeable stop disks. All shrink fit chucks with a diameter of 3 to 32 mm can be heated with a single coil. Just 5 stop disks are enough to adapt the coil to each chuck, from the smallest to the largest.

#### The NG coils (New Generation)

The intelligent NG coils are particularly flexible and comfortable. They are adjustable. With one turn, you can set the coil to the size of the shrink fit chucks, both in length and diameter. Stop disks are no longer necessary. This means the chuck is only heated where it is intended. Even with special sizes.

#### Power electronics

The second component of shrink fit technology is power electronics. It supplies the coil with power. Frequency and current must be exactly coordinated with one another to do this. Heating must take place within seconds, without overheating the chuck. A specially developed procedure for power regulation makes sure this is the case, independent of the main voltage. HAIMER offers shrink fit equipment with an output of 10 to 20 kW.

#### Operation

Equally decisive for the success of an investment is its acceptance among your employees. A machine, which is used happily and frequently, pays for itself within a short period of time. HAIMER shrink fit equipment can be equipped for any purpose and need. From a simple device with one shrink fit station and no cooling, up to fully equipped machines with rotary table, integrated contact cooling and system cart.

## 接觸式冷卻 THE CONTACT COOLING



### 接觸式冷卻

HAIMER獨有的專利冷卻系統是燒結刀柄最快速，最清潔的冷卻方式。

每種刀柄都有適合的冷卻套，冷卻套安放在刀柄上與外表面接觸，透過熱傳導將熱量帶走。冷卻水在冷卻套內循環流動。

個冷卻過程溫和且均勻，刀柄不會任何變形，偏擺精度被保證不變。

刀柄不會與冷卻水接觸，保證乾燥不會生銹，工作環境乾淨整潔。

### 快速冷卻的冷卻套

- 冷卻時間：約 30 秒
- 刀桿保持乾燥清潔
- 防止生銹
- 無需花費時間等候乾燥
- 即使被冷卻，偏擺精度也保持不變
- 加熱的部分全面被覆蓋，無燙傷的危險
- 不會接觸加熱部分
- 冷卻過程溫和和安全，不會發生意外
- 冷卻套不會變熱，即使冷卻了很多燒結刀具，熱量全部被冷卻水循環帶走
- 5種冷卻套適合所有的標準刀柄
- 冷卻水不會滲漏，工作環境乾淨整潔

### Contact Cooling

The patented cooling system from HAIMER is the quickest and cleanest method of cooling shrink fit chucks.

There is a suitable cooling body for every chuck. The cooling body sits with the surface contact on the chuck and removes the heat from it. A water cycle cools the cooling body in turn.

The cooling procedure takes place completely evenly and gently. There is no deformation of the chuck. The runout accuracy is preserved.

The chucks do not come into contact with the water. They remain dry and do not rust. The work place also remains clean and dry.

### Cooling body for rapid cooling

- Cooling in record time: approx. 30 s
- Tool holders remain dry
- No build-up of rust
- No time lost through drying process
- Even cooling, runout accuracy is maintained
- Hot points are always covered, no risk of injury
- Hot parts need not be touched
- Gentle handling of chuck, no shocking
- No heating of cooling body, even after lots of shrink fit procedures: heat is removed with water cycle
- 5 cooling bodies for all standardized chucks
- No dripping water, always a clean work space

## 燒結機系統：基本型/進階型/豪華型

### THE POWER CLAMP SYSTEM: PROFI LINE/PREMIUM LINE

Haimer有最好的燒結加熱技術，可以適合各種需求，有最大使用範圍的線圈與系統設計。

**HAIMER has the right Shrink fit technology for any need. Take advantage of the largest range of shrink fit equipment and coils in the world.**

#### 基本型：最適合於基本需求的機型

基本型的燒結機系列是導入燒結機系列的入門機種，強力的燒結技術確保最佳的效能，操作容易，只有單支的刀具座，配備有標準的燒結線圈，適合刀具交換次數較少的使用者。

適用於特殊臥式微細加工需求，非Power Clamp Nano刀桿燒結機莫屬，它完美的結合最小型刀具便利操作及快速換模的功能。

#### Basic Line: Concentrating on the basics.

The Basic Line is the economical entrance into inductive shrink fit technology. The power electronics enables problem free shrinking. The mechanical construction of the equipment has, on the other hand, been kept deliberately simple and functional. There are just single chuck solutions.

The Basic Line equipment is exclusively designed for operation with standard coils. It is not possible to upgrade.

The Basic Line is ideal for the price-conscious user, who only wants to shrink a few tools on a daily basis.

For micro machining purposes the special horizontal shrink fit machine Power Clamp Nano is part of the program. It combines perfectly easy tool handling of small diameters and fast tool exchange.

#### 進階型：模組化的變化應用

進階型的燒結機系列產品提供了模組化的設計，供應了最高效率的產品與泛用性，可以選擇高效能的新一代燒結線圈，接觸式冷卻系統與三孔迴轉式刀具座，可以同時燒結刀具與冷卻刀具。

進階型燒結機可以選用標準線圈與新一代線圈，智慧型的電子系統會自動判斷線圈種類與刀具規格，提供最適當的加熱電流與參數。

模組化的設計方式，可以從最經濟的組合，與升級到最高級的機型都使用相同的電子系統，確保投資的效益。

#### Profi Line: Modular All-rounder.

The Profi Line offers the full range of performance and is unbeatable in efficiency. High performance coils, contact cooling and rotary table guarantee simultaneous shrinking and cooling in record time. No wishes remain unfulfilled.

The machines of the Profi Line work with both the standard coils and the intelligent and comfortable NG coils. Of course, the equipment recognizes each coil and chooses the correct shrink fit parameters automatically.

The shrink fit machines of the Profi Line form a modular system. The start-up machine Power Clamp Economic can gradually be upgraded to the high-end unit Power Clamp Comfort NG.

#### 豪華型：完善功能

豪華型的燒結機系列產品為滿足最頂級要求的設計，在於豪華型燒結機提高其使用多重便利性及滿足客戶每天工作上的需求，成為客戶最佳仰賴的刀桿燒結技術產品。

配備引導冷卻水套固定位置的冷卻方式，使不同直徑刀桿在這些機台上端，可便利達到冷卻效果。

安全性和服務也是豪華型燒結機系列考慮的重點，在冷卻過程中能自動控制溫度的高低。

豪華型燒結機系列是模組化的設計，能根據需求配置不同的功能。

#### Premium Line: Perfection in detail.

The Premium Line is the series for highest demands.

The shrink fit machines of this line are perfectly suitable for users relying on this clamping technology due to its various advantages and accordingly having many shrink fit jobs a day.

The idea of fixed cooling stations equipped with guided cooling bodies of different diameter simplifies the handling of these high-end machines.

The aspect of service and safety is considered intensively for the Premium Line, too, as the cool-down process is terminated temperature controlled automatically.

The Power Clamp Premium series is a modular system and the machines are to be configured up on request.

# HAIMER 燒結機的投資回收期 AMORTISATION HAIMER POWER CLAMP

以下的圖表提示了燒結機的投資回收期/ The following diagram shows the short amortisation periods.

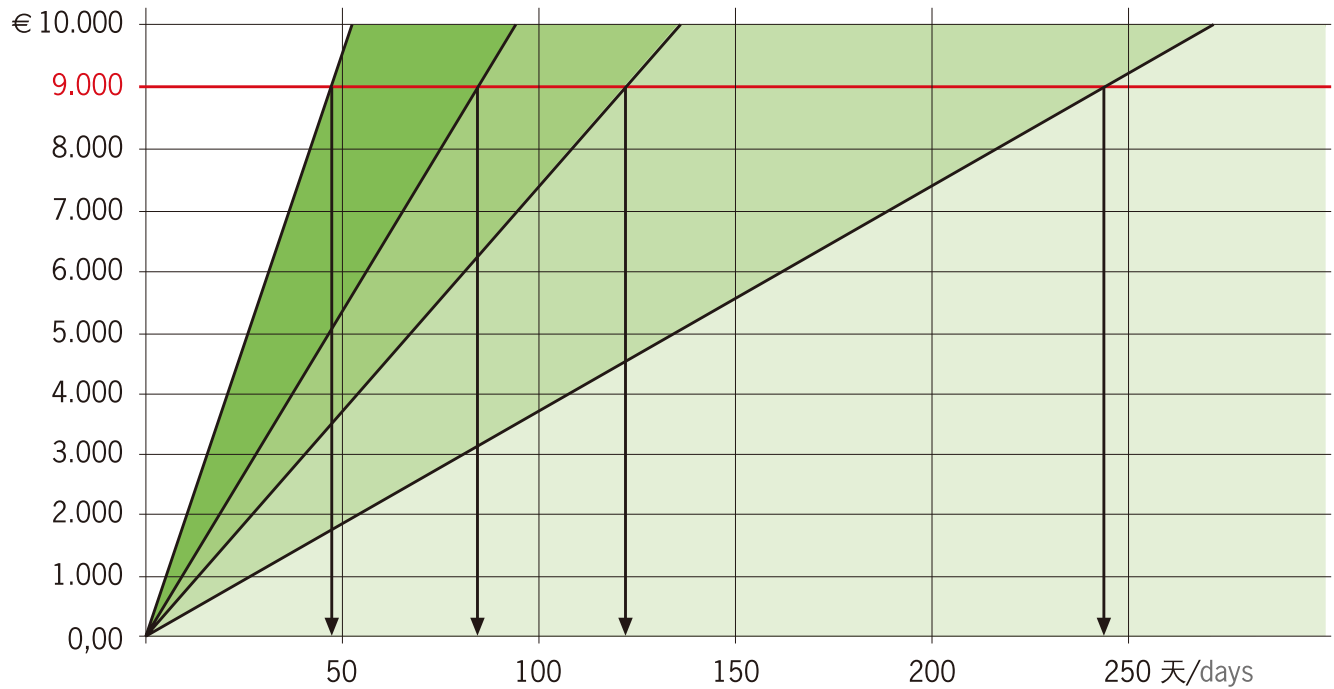

回收期  
Amortisation period

每日換刀次數 /

50次/日  
50 jobs/day

30次/日  
30 jobs/day

20次/日  
20 jobs/day

10次/日  
10 jobs/day

## 訂購價格 / Purchase price

與沒有使用快速冷卻系統的燒結系統比較，  
Haimer的系統每換一支刀可以節省5分鐘時間。  
整體而言，一年之內您的投資一定可以回收!

Amortisation Power Clamp NG  
with Speed Cooler dependent on the number of shrink cycles per day.  
Saving of time: 5 min. per cycle  
Cost set: 50 €/h

NANO 臥式刀桿燒結機 / POWER CLAMP NANO

適用於刀桿的燒結機

- 功率:13kW
- 電壓:3相x400-480 Volt, 16A
- 適用刀具: 直徑 $\phi 3 \sim \phi 16$ mm的碳化鎢與高速鋼
- 臥式結構方便操作

Simple shrink fit machine for small tools.

- Power: 13 kW
- Mains voltage: 3 x 400 – 480 V, 16 A
- Tools: solid carbide and HSS from  $\phi 3 - \phi 16$  mm
- Easy tool handling by horizontal shrinking



**定位環**  
Stop disc  
訂購編號: 80.162.00

**刀桿夾持座**  
Chuck support for tool holders with bajonet clamping  
訂購編號: 80.16...

**長度設定的校驗轉換套**  
適用於測量設備的預設。  
Calibration adapter for length presetting  
For resetting of the measuring device  
訂購編號: 80.165.01

**刀具夾 (選購品)**  
用於安全並精確地操作高品質的硬質合金刀具-特別適用於小的直徑。  
Clips for tools  
For safest and precise handling of high quality carbide tools - especially for smaller diameters  
訂購編號: 80.160.xx 03....16

**空氣冷卻機**  
選配的壓縮空氣冷卻系統, 適用於安全的操作小刀具。  
Air cooling  
Cooling by compressed air, regardless of contour and safest handling for small tool holders  
訂購編號: 80.164.02  
小徑刀具冷卻套

**長度設定 (選購品)**  
水平長度設定單元  
精度: 0.01mm  
Length presetting  
Horizontal length presetting unit  
Tolerance 0.01 mm  
訂購編號: 80.165.00

技術資料 / Technical details		訂購編號 / Order No.							
<b>Power Clamp Nano/Nano 臥式刀桿燒結機</b>		<b>80.160.00</b>							
電壓 / Mains voltage	3相x 400-480 Volt, 16A, 13 kW								
適用刀具 / Tools	碳化鎢和高速鋼 / solid carbide and HSS								
適用刀具直徑 / Tool diameter	3 - 16mm								
最大刀長 / Maximum Length of shrink fit chuck	230mm								
機器尺寸 / Dimensions	630 x 510 x 630 mm								
機器重量 / Weight	75 kg								
<b>相關配件 / Accessories</b>									
刀桿規格 / Type	SK/BT30 SK40 BT40 HSK25 HSK32 HSK40 HSK50 HSK63								
單孔刀桿支持座 / Chuck support for single-chuck system	...2.30 ...2.40.01 ...2.40.06 ...3.25 ...3.32 ...3.40 ...3.50 ...3.63								
訂購編號 / Order No.	80.16...								
<b>氣冷式 燒結式刀桿冷卻機 / Power Clamp Nano Air Cooling</b>		<b>80.164.00</b>							
<b>長度設定裝置 / Length presetting</b>		<b>80.165.00</b>							
刀具夾持筒夾 / Clips for tools for length presetting	$\phi 3$ mm $\phi 4$ mm $\phi 5$ mm $\phi 6$ mm $\phi 8$ mm $\phi 10$ mm $\phi 12$ mm								
訂購編號 / Order No.	80.166... ..0.3 ..0.4 ..0.5 ..0.6 ..0.8 ..0.10 ..0.12								
<b>刀具夾持筒夾組 (包含底座) / Set of clips incl. plate</b>		<b>80.166.00</b>							



## 基本型系列-刀桿燒結機 POWER CLAMP BASIC LINE



### 刀桿燒結機/基本型 POWER CLAMP BASIC

適合所有的刀具(全碳化鎢與高速鋼刀具HSS)

- 功率:10KW
- 電壓:3相 / 400~480V,16A
- 適用刀具:直徑:Ø3~32mm的碳化鎢和高速鋼
- 包含一個刀具底座

**Standard shrink fit machine for all tools (solid carbide and HSS).**

- Power: 10 kW
- Mains voltage: 3 x 400 – 480 V, 16 A
- Tools: solid carbide and HSS from Ø 3 – 32 mm
- With 1 base holder



新型 Easy Cooler 氣冷式燒結式刀桿冷卻機組可與Power Clamp Basic燒結機完美結合，快速輕鬆地冷卻燒結刀桿。

### 氣冷式 燒結式刀桿冷卻機 EASY COOLER

HAIMER的Easy Cooler適用於各式燒結刀桿的新型吹氣冷卻裝置，燒結刀桿適用尺寸範圍為 Ø3 mm – 32 mm

- 獨立操作機型。
- 不受限燒結刀桿各種角度或ER剛性筒夾的外型輪廓，皆可以適用。
- 與Power Clamp Basic燒結機同一高度水平，方便輕鬆移動刀桿支撐底座冷卻燒結刀桿。
- 透過空氣壓縮操作冷卻燒結刀桿，無需電源供應。

**Air cooling made easy:**

The Easy Cooler from HAIMER is the new cooling device for tool holders and shrink fit collets from Ø 3 mm – 32 mm.

- Also possible as stand-alone unit
- Contour-independent cooling of tool holders and shrink fit collets
- One height level with Power Clamp
- Basic for easy movement of the base holders
- Operates via compressed air, no power supply necessary.

#### 技術資料 / Technical details

訂購編號 / Order No.

#### Power Clamp Basic/刀桿燒結機-基本型

80.150.00

電壓/Mains voltage	3相/400~480 V, 16A,10KW
適用刀具/Tools	全碳化鎢和高速鋼刀具HSS/solid carbide and HSS
適用刀具直徑 Tool diameter	3-32 mm
最大刀長 Maximum Length of shrink fit chuck	350 mm
機器尺寸 Dimensions	650x900x600 mm
機器重量 Weight	45 Kg

#### Easy Cooler/氣冷式 燒結式刀桿冷卻機

PC900-C22

空氣壓力 /Air pressure	6 bar
適用刀具 /Tools	全碳化鎢和高速鋼刀具HSS/ Solid carbide and HSS
適用刀具直徑 /Tool diameter	3-32 mm
最大刀長 /Maximum Length of shrink fit chuck	350 mm
機器尺寸 /Dimensions	350x570x1055 mm

#### 相關配件 / Accessories

刀桿規格/Type	SK30	SK 40	SK 50	HSK 32	HSK 40	HSK 50	HSK 63	HSK 80	HSK 100
單孔刀桿支持座/Chuck support for single-chuck system 訂購編號/Order No. 80.11	...2.30	...2.40	...2.50	...3.32	...3.40	...3.50	...3.63	...3.80	...3.10

技術資料內容變動，恕不另行通知 / Technical data subject to change without prior notice

逐步的擴充燒結機的特性

燒結機基本單元可以搭配兩種不同的背板, 刀具支持座也可以從單孔升級為三孔迴轉式的設計。

Step by step more shrink fit technology.

Basic unit can be combined with two rear walls and two base plates. The chuck support for the rotary table will be supplied as requested.

背板含快速冷卻套與快速冷卻機  
Speed Cooler Upgrade Kit

線圈導軌  
Coil Guidance

燒結機底座  
Power Clamp base unit

旋轉支撐座, 儲物盒與能儲放刀具的鋁製  
檯面

Base plate Standard made of aluminum with rotary table, integrated tool tray and craning boxes

經濟型背板  
Rear wall Economic

可旋轉式刀具支撐座根據  
需求安裝  
Chuck support for rotary  
table as requested

單刀柄支撐系統  
Base holder/Chuck support for single-chuck  
system

刀具設定長度升級組合  
Preset Upgrade Kit

經濟型和經濟進階型用, 刀具儲放盤的台面  
Base plate Economic and ECONOMIC PLUS  
with integrated tool tray

刀具儲放盤  
Tool tray for storage of tools

Power Clamp		訂購編號 /Order No.
冷卻系統升級組合 Speed-Cooler Upgrade Kit	冷卻機系統含冷卻套放置背板, 與五個冷卻水套 Speed-Cooler with rear wall incl. 5 cooling bodies	80.115.00
旋轉式支撐盤組合 (舒適型) Rotary table Upgrade Kit (= Power Clamp Comfort)	刀具儲放盤可放置三支刀桿的支持作迴轉盤 Base plate with rotary table for 3 chucks incl. craning boxes	80.116.00
刀長設定系統升級組合 Preset Upgrade Kit	含量測板, 數字型高度規, 兩個精密基座 Measuring plate, height gage, 2 precision base holder incl. craning boxes	80.117.00

## 進階型系列-刀桿燒結機 POWER CLAMP PROFI LINE PROGRAM



NG經濟型燒結機不含冷卻系統，無旋轉盤，附刀具儲放盤

Power Clamp Economic NG without cooling, without rotary table, with integrated tool tray

技術資料 / Technical details

訂購編號 / Order No.

Power Clamp Economic NG/ 新式專業經濟型燒結機

80.110.00NG



進階新式專業經濟型燒結機含冷卻系統，不含旋轉式支撐座，含單支撐座，刀具儲放盤。

Power Clamp Economic Plus NG with cooling, without rotary table, incl. 1 base holder and 1 chuck support, with integrated tool tray

Power Clamp Economic Plus NG/進階新式專業經濟型燒結機

訂購編號 / Order No.

80.110.01NG



高階新式專業型燒結機含冷卻系統，旋轉式支撐座，儲物盒。

Power Clamp Comfort NG with cooling, rotary table, 1 chuck support, integrated tool tray and craning boxes

Power Clamp Comfort NG/高階新式專業型燒結機

訂購編號 / Order No.

80.100.00NG



高階專業型燒結機

– 功率：20kW

– 可加熱刀具直徑範圍：Ø3-50mm

– 適合加熱碳化鎢與高速鋼刀具

– 可安裝大型線圈：刀桿直徑Ø40-50 mm (選購品)

– 含旋轉支撐座

– 含刀具儲放盤

– 含儲物盒

Power Clamp Profi Plus NG

High powered shrink fit machine

– Heating power 20 kW

– For shrinking of tools from Ø 3–50 mm

– For HSS- and solid carbide tools

– Big coil for Ø 40–50 mm (optional)

– Incl. rotary table and chuck support

– Incl. tool tray

– With craning boxes for accessories

Power Clamp Profi Plus NG/高階專業型燒結機

訂購編號 / Order No.

80.100.10NG

技術資料 / Technical details

主機規格 3相x 400-480 Volt, 16A, 13 kW

Basic unit Comfort

最大刀柄長度 (可根據要求加長) 510mm

Maximum length of shrink fit chuck (longer chucks upon request)

機器尺寸 / Dimensions 860 x 600 x 990 mm

機器重量 / Weight 70 kg

冷卻單位 Speed-Cooler unit 230Volt, 50Hz, 1 kW

機器尺寸 / Dimensions 565 x 450 x 320 mm

機器重量 / Weight 45 kg

技術資料內容變動，恕不另行通知 / Technical data subject to change without prior notice

進階型燒結機系列 / POWER CLAMP PROFI LINE  
HAIMER NG燒結機 / HAIMER POWER CLAMP NEW GENERATION

智慧型專利線圈技術：

線圈可以根據刀桿調整長度與直徑，因此只有夾持刀具的區域被加熱 – 其他位置不會被加熱，加熱和冷卻速度更迅速。



更有效，更靈活，操作更簡單

- 線圈根據刀桿調整
- 由於線圈長度調整，磁場分佈完美
- 由於線圈長度調整，熱量分佈最佳
- 短刀桿亦可加熱
- 縮短加熱時間
- 縮短冷卻時間
- 操作簡單
- 不需要定位環
- 適合T型槽銑刀
- 適合超短刀桿
- 適合特殊形狀的刀桿

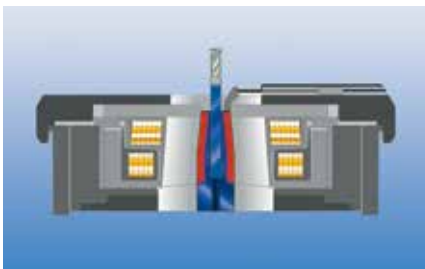

小直徑/Small tool

Intelligent patented coil technology:

The coil adjusts itself to the chuck in length and diameter. Therefore only the shrinking area of the chuck will be warmed – nothing else. Shrinking and cooling will be much faster.

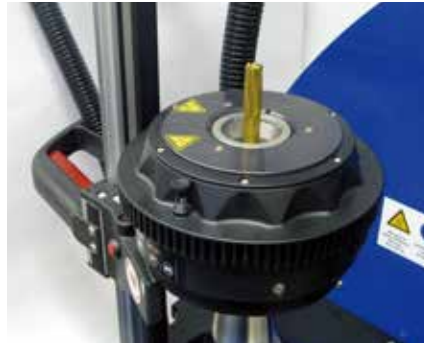

Even more efficiency, more flexibility, easier handling.

- Coil adjusts itself to the chuck
- Perfect magnetic flow due to length adjustment of the coil
- Optimal heat distribution due to length adjustment of the coil
- Lower chuck warming
- Shorter shrinking time
- Shorter cooling time
- Simple operation
- No contact discs necessary any more
- Suitable for T-shaped groove milling cutters
- Suitable for ultra-short chucks
- Suitable for special shape

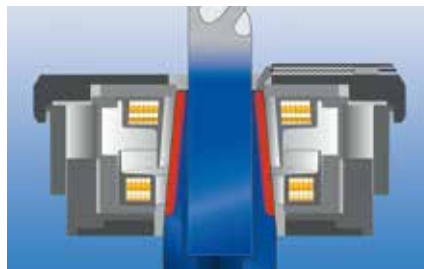

大直徑/Big tool

單手操作

- 線圈定位與開始加熱僅需單手即可完成

Single hand operation

- Positioning of coil and starting of shrink process with one hand

旋轉盤

- 工作迅速且有效
- 可同時加與熱冷卻-有三個刀具放置位置
- 節約時間

The turning table

- Work fast and efficient
- Heating and cooling at the same time on 3 stations
- No idle periods



支撐盤/Chuck support

三支刀具支撐盤

- 適合所有刀桿規格
- 不同刀桿錐度的規格可以任意組合
- Chuck support for 3 chucks
- For all actual tapers
- Also different tapers combined possible

**適用於快速冷卻的冷卻套**

- 刀桿保持乾燥
- 不會生銹
- 加熱部分被覆蓋
- 無燙傷危險
- 不會接觸加熱部位

**Cooling bodies for rapid cooling**

- Chucks remain dry
- No rust
- Hot spots always covered,
- no danger of injury
- Hot parts need not to be taken into the hand

**特色**

- 人性化的操作面板
- 清晰，緊湊容易操作

**The display**

- User-friendly operating panel
- Clear, compact and easy to handle

**刀具儲放盤**

- 適合儲放刀具
- 一體設計在底板上

**The tool tray**

- For laying down cutting tools
- Integrated in base plate

**儲物盒**

- 適合存放配件
- 方便拿取

**The craning boxes**

- For accessories
- Everything close at hand

**系統工具車**

- 佈局合理符合人體工學的工作設計

**The system cart**

- For a clearly arranged and ergonomic work place

**抽屜**

- 配合各種附件的輪廓設計
- 每個附件都有放置處

**The drawer**

- Profiled inserts for accessories
- Everything in its place

圖片顯示的是舒適型燒結機含附件組與工具車  
Picture shows Power Clamp Comfort with accessories and system cart



### 進階專業經濟型燒結機

#### POWER CLAMP ECONOMIC PLUS SPECIAL EDITION

高效能燒結機,適合所有的刀具使用:

- 線圈:標準燒結線圈,需要更換定位環
- 單孔刀桿支持座
- 含接觸式高效率冷卻機與冷卻水套
- 功率:13KW
- 電壓:3相/400~480V,16A
- 適用刀具直徑:Ø3-32mm,全碳化鎢與高速鋼刀具HSS

#### High performance shrink fit machine for all tools.

- With standard coil
- Single chuck version
- With integrated contact cooling
- With 1 base holder
- Incl: Cooling Manager
- Power: 13 kW
- Mains voltage: 3 x 400 – 480 V, 16 A
- Tools: solid carbide and HSS from Ø 3 – 32 mm



### 進階新式專業經濟型燒結機

#### POWER CLAMP ECONOMIC PLUS NG

高效能燒結機,適合所有的刀具使用:

- 線圈:新式燒結線圈,調整刀具尺寸,不需要更換定位環
- 單孔刀具座
- 含接觸式高效率冷卻機與冷卻水套
- 包含一個刀具底座
- 包含一個刀桿支持座
- 包含冷卻水套基座
- 功率:13KW
- 電壓:3相/400~480V,16A
- 適用刀具直徑:Ø3-32mm,全碳化鎢與高速鋼刀具HSS

#### High performance shrink fit machine for all tools.

#### Upgrade possible with HD coil for shrinking of Heavy Duty Shrink Chucks up to Ø 50 mm (on option)

- With intelligent NG coil
- Single chuck version
- With integrated contact cooling
- With 1 base holder
- Incl. Cooling Manager
- Power: 13 kW
- Mains voltage: 3 x 400 – 480 V, 16 A
- Tools: solid carbide and HSS from Ø 3 – 32 mm

#### 技術資料/ Technical details

#### 訂購編號 /Order No.

**Power Clamp Economic Plus Special Edition/ 進階專業經濟型燒結機**

**80.110.01SE**

**Power Clamp Economic NG/ 新式專業經濟型燒結機**

**80.110.01NG**

電壓 Mains voltage

3相/400~480V, 16A, 13KW

適用刀具/Tools

碳化鎢和高速鋼刀具 solid carbide and HSS

適用刀具直徑 Tool diameter

3-32 mm

最大刀長 Maximum Length of shrink fit chuck

Economic Plus/專業經濟型燒結機:510 mm Economic NG/新式專業經濟型燒結機:570mm

機器尺寸 Dimensions

860×600×990 mm

機器重量 Weight

70 Kg

#### 相關配件/Accessories

儲物盒/Cranning boxes

**80.134.00NG**

支撐盤/Chuck support for single-chuck system

詳情請參見P21/See page21

進階新式專業經濟型燒結機升級用13kW HD 線圈/Upgrade Kit 13kW HD coil for Economic Plus NG

**80.151.30.10**

進階型系列-刀桿燒結機/PROFI LINE  
高階機型/HIGH-END MODEL



高階專業型燒結機  
POWER CLAMP COMFORT

高效能燒結機,適合所有的刀具使用:

- 線圈:標準燒結線圈,需要更換定位環
- 三孔迴轉式刀具座
- 含接觸式高效率冷卻機與冷卻水套
- 包含冷卻水套基座
- 包含一個刀具座和迴轉式刀桿支持座
- 功率:13KW
- 電壓:3相/400~480V,16A
- 適用刀具直徑:Ø3-32mm,全碳化鎢與高速鋼刀具HSS

High performance shrink fit machine for all tools.

- With standard coil
- Rotary table with 3 stations
- With integrated contact cooling
- Incl. Cooling Manager
- With 1 chuck support for rotary table
- Without craning boxes
- Power: 13 kW
- Mains voltage: 3 x 400 – 480 V, 16 A
- Tools: solid carbide and HSS from Ø 3 – 32 mm



高階新式專業型燒結機  
POWER CLAMP COMFORT NG

高效能燒結機,適合所有的刀具使用:

- 線圈:標準燒結線圈,調整刀具尺寸,不需更換刀具定位環
- 三孔迴轉式刀具座
- 含接觸式高效率冷卻機與冷卻水套
- 包含冷卻水套基座
- 包含一個刀具座和迴轉式刀桿支持座
- 功率:13KW
- 電壓:3相/400~480V,16A
- 適用刀具直徑:Ø3-32mm,全碳化鎢與高速鋼刀具HSS

High performance shrink fit machine for all tools.  
Upgrade possible with HD coil for shrinking of Heavy Duty Shrink Chucks up to Ø 50 mm (on option)

- With intelligent NG coil
- Rotary table with 3 stations
- With integrated contact cooling
- Incl. Cooling Manager
- With 1 chuck support for rotary table
- With craning boxes
- Power: 13 kW
- Mains voltage: 3 x 400 – 480 V, 16 A
- Tools: solid carbide and HSS from Ø 3 – 32 mm

技術資料 / Technical details

訂購編號 /Order No.

Power Clamp Comfort/高階專業型燒結機	80.100.00
Power Clamp Comfort NG/高階新式專業型燒結機	80.100.00NG
電壓 Mains voltage	3相/400~480 Volt, 16A,13KW
適用刀具/Tools	碳化鎢和高速鋼刀具 solid carbide and HSS
適用刀具直徑 Tool diameter	3-32 mm
最大刀長 Maximum Length of shrink fit chuck	Power Clamp Comfort/高階專業型燒結機:510 mm    Comfort NG/高階新式專業型燒結機:570mm
機器尺寸 Dimensions	860×600×990 mm
機器重量 Weight	70 Kg

相關配件 / Accessories

儲物盒/Cranning boxes	80.134.00NG
支撐盤/Chuck support for single-chuck system	詳情請參見P23/See page23
高階新式專業型燒結機升級用13kW HD 線圈/Upgrade Kit 13kW HD coil for Power Clamp Comfort NG	80.151.30.10



高階專業型燒結機

POWER CLAMP PROFI PLUS NG

高效能燒結機, 適合所有的刀具使用:

- 線圈: 標準燒結線圈, 不需要更換定位環
- 三孔迴轉式刀具座
- 含接觸式高效率冷卻機與冷卻水套
- 附加線圈適合刀具直徑: Ø40-45mm
- 包含一個適合迴轉式刀具座的三孔刀桿支持座
- 功率: 20KW
- 電壓: 3相/400~480V, 32A
- 適用刀具直徑: Ø3-50mm, 全碳化鎢與高速鋼刀具HSS

High performance shrink fit machine for all tools.

- With intelligent NG coil
- Rotary table with 3 stations
- With integrated contact cooling
- Incl. Cooling Manager
- Optional with second coil for Ø 40 – 50 mm
- With 1 chuck support for rotary table
- Power: 20 kW
- Mains voltage: 3 x 400 – 480 V, 32 A
- Tools: solid carbide and HSS from Ø 3 – 50 mm



刀具設定型新式燒結機

POWER CLAMP PRESET NG

高效能燒結機, 適合所有的刀具使用:

- 包含刀長設定裝置
- 線圈: 新式燒結線圈, 調整刀具尺寸, 不需要更換刀具定位環
- 單孔刀具座
- 含接觸式高效率冷卻機與冷卻水套
- 包含二個刀桿底座
- 包含二個刀桿支持座
- 包含冷卻機管理功能
- 功率: 13KW
- 電壓: 3相/400~480V, 16A
- 適用刀具直徑: Ø3-32mm, 全碳化鎢與高速鋼刀具HSS

High performance shrink fit machine for all tools.

Upgrade possible with HD coil for shrinking of Heavy Duty Shrink Chucks up to Ø 50 mm (on option)

- With vertical stop for length presetting
- With intelligent NG coil
- Single chuck version
- With integrated contact cooling
- Incl. Cooling Manager
- With 2 precision base holders
- Power: 13 kW
- Mains voltage: 3 x 400 – 480 V, 16 A
- Tools: solid carbide and HSS from Ø 3 – 32 mm

技術資料 / Technical details

訂購編號 / Order No.

<b>Power Clamp Profi Plus NG/ 高階專業型燒結機</b>		<b>80.100.10NG</b>
電壓與功率 Main voltage	3相/400~480 Volt, 32A, 20KW	
<b>Power Clamp Preset NG/刀長設定型與新式燒結機</b>		<b>80.130.00NG</b>
電壓與功率 Main voltage	3相/400~480 Volt, 16A, 13KW	
適用刀具 Tools	碳化鎢和高速鋼刀具 solid carbide and HSS	
適用刀具直徑 Tool diameter	3-32 mm	
最大刀桿長度 Maximum Length of shrink fit chuck	570 mm	
機器尺寸 Dimentions	860×600×990 mm	
機器重量 Weight	85 Kg	

相關配件 / Accessories

高階專業型燒結機/Power Clamp Profi Plus NG Chuck support for ratary table	詳情請參見P23/See page23
升級用13kw HD線圈/Upgrade Kit 13kW HD coil	<b>80.151.30.10</b>
刀長設定型新式燒結機精密支撐盤/Power Clamp preset NG Precision chuck support	詳情請參見P22/See page22



## 豪華型燒結式刀桿燒結機/POWER CLAMP PREMIUM LINE 適用於追求完美的您/FOR PERFECTIONISTS

### 豪華型系列-刀桿燒結機 POWER CLAMP PREMIUM LINE



照片上機型  
80.170.00NG  
長度設定量測單元(選配)  
Picture shows 80.170.00NG  
with optional length presetting

擁有完美操控性的高階加熱設備,含最大冷卻系統  
5個冷卻水套:

- 功率:13KW
- 電壓:3相x400-480V,16A
- 適用刀具直徑:Ø3-32mm碳化鎢與高速鋼
- V2008標準燒結線圈,可選配NG線圈
- 含接觸式高效率冷卻機與5個冷卻水套
- 不會損壞切削刀具的刃口
- 包含快速冷卻
- 包含冷卻機管理功能
- 包含2個刀具底座
- 包含2個精密的刀桿支持座
- 內建抽屜一組

High-end shrink fit machine for perfect handling and  
simultaneous cool-down at max. five cooling stations.

- Power: 13 kW
- Mains voltage: 3 x 400 – 480 V, 16 A
- Tools: solid carbide and HSS from Ø 3 – 32 mm
- With standard coil V2008, NG coil optional
- TME Intelligent Cooling System with temperature control
- Integrated contact cooling with five cooling bodies
- Linear guided cooling bodies
- No damage at the edges of the cutting tool
- Incl. Speed Cooler and Cooling Manager
- Incl. 2 precision base holders
- Integrated drawer

#### 技術資料/ Technical details

#### 訂購編號 /Order No.

Power Clamp Premium/ 豪華型燒結機	80.170.00
Power Clamp Premium NG/NG豪華新式豪華型燒結機	80.170.00NG
電壓 Mains voltage	3相/400-480 Volt, 16A,13KW
適用刀具/Tools	碳化鎢和高速鋼刀具 solid carbide and HSS
適用刀具直徑 Tool diameter	3-32 mm
最大刀長 Maximum Length of shrink fit chuck	Premium:475mm/ Premium NG:535mm
機器尺寸 Dimensions	1130x800x2000 mm
機器重量 Weight	300 Kg

#### 相關配件/ Accessories

豪華型燒結機專用系統工具車/System cart Premium	80.124.20
精密支撐盤/Precision chuck support	詳情請參見P22/See page22
精密支撐座/Precision base holder for chuck support	80.131.00
刀具預設長度/Length presetting	80.178.00

技術資料內容變動,恕不另行通知 /Technical data subject to change without prior notice

超級型系列-刀桿燒結機  
POWER CLAMP PREMIUM PLUS



擁有絕對可靠性的高階加熱設備, 配備兩個獨立的電子裝置和線圈。

- 功率: 33KW
- 電壓: 3相x400V, 63A
- 適用刀具直徑: Ø3-50mm 碳化鎢與高速鋼
- VS32h 新式燒結智能線圈, 和 20KW 線圈
- 6個接觸式冷卻水套
- 不會損壞切削刀具的刃口
- 冷卻水套在冷卻過程結束後會自動向上拉升(溫度可控制)
- 兩套高度設定裝置
- 包含冷卻機管理功能
- 高度定位的2個長度設定單元
- 包含2個刀具底座和2個刀桿支持座
- 包含3個集成式抽屜

High-end shrink fit machine for absolute process reliability with two separate electronic units and two coils.

- Power: 33 kW
- Mains voltage: 3 x 400 V, 63 A
- Tools: solid carbide and HSS from Ø 3 – 50 mm
- With intelligent coil VS32 m and 20 kW coil
- TME Intelligent Cooling System with temperature control
- Automatic move-up of the cooling bodies after the termination of the cooling process (temperature-time controlled)
- Integrated contact cooling with six cooling bodies
- Linear guided cooling bodies
- No damage at the edges of the cutting tool
- Incl. Cooling Manager
- Two length presetting units with height stop
- Incl. 2 precision base holders and 2 precision chuck supports
- 3 integrated drawers

技術資料 / Technical details

訂購編號 / Order No.

**Power Clamp Premium Plus/ 高階超級型燒結機**

**80.170.10**

電壓 / Mains voltage	3相/400 Volt, 63 A, 33KW
適用刀具 / Tools	碳化鎢和高速鋼刀具 / solid carbide and HSS
適用刀具直徑 / Tool diameter	3-50 mm
最大刀長 / Maximum Length of shrink fit chuck	535mm
機器尺寸 / Dimensions	1600x850x2300 mm
機器重量 / Weight	550 Kg

相關配件 / Accessories

精密支撐盤 / Precision chuck support

詳情請參見 P22 / See page 22

精密支撐座 / Precision base holder for chuck support

**80.131.00**

## 工具車與配件 CARTS AND INSERTS



### 系統型工具車

- 燒結機專用工具車, 可以放置燒結機與各種配件
- 整理出乾淨與方便的工作空間
- 人體工學的工作高度
- 取用各種配件最方便
- 選購: 配件整理板

### System cart

- Cart for shrinking machine and accessories
- For a clear and tidy work space
- Ergonomic work height
- Everything at hand
- Optional: Drawers with inserts to store accessories

訂購編號 /Order No.

系統型工具車 System cart (1000x620x840mm) **80.124.00**

系統型工具車 價格另議 System cart Premium (1130x690x840mm) **80.124.20**



### 配件整理板 (不含配件)

### Drawer insert for system cart (does not include accessories)

訂購編號 /Order No.

抽屜 / Drawer **80.124.04**



### 簡易型工具車

### Cart for shrink fit machine

訂購編號 /Order No.

工具車 / Cart **80.106.00**



圖.1  
Fig. 1

適用於所有尺寸的刀桿支撐盤：

兩種形式可供選擇：

圖1：  
適用於基本型 / 經濟型 / 經濟進階型燒結機的支撐座

圖2：  
適用於刀長設定型 / 豪華型 / 豪華加強型燒結機的精  
密支撐座  
為了達到最佳精度，精密支撐座的每個功能面都被  
精磨與固定的高度



圖.2  
Fig. 2

To hold chuck supports of all sizes.

Available in two versions:

Fig. 1:  
Base holder for Power Clamp Basic/Economic/Economic Plus

Fig. 2:  
Precision base holder for Power Clamp Preset/Premium/Premium  
Plus  
High precision version with fine machined functional surfaces for  
maximum precision at length presetting

技術資料 / Technical details

訂購編號 / Order No.

適合於基本型 / 經濟型 / 經濟進階型燒結機的支撐座 / Base holder for Power Clamp Basic/Economic/Economic Plus

**113004-0148**

適合於刀長設定型 / 豪華型 / 豪華加強型燒結機的支撐座 / Precision base holder for Power Clamp Preset/Premium/Premium Plus

**80.131.00**

## NANO 燒結機用支撐座 CHUCK SUPPORT FOR POWER CLAMP NANO

NANO燒結機用支撐座  
臥式燒結機Nano燒結機用支撐座

-適用於刀桿錐度規格SK30 - SK50,  
BT30 - BT40, JBS T15, HSK-25 - HSK-63

Chuck support for horizontal shrink fit machine  
Power Clamp Nano.

Available in taper sizes SK30 – SK50,  
BT30 – BT40, JBS T15, HSK-25 – HSK-63



單支撐盤適用於 / Chuck support for  
Nano燒結機 / Power Clamp Nano

訂購編號 / Order No.	錐度尺寸 / for taper size
80.162.30	IN 69872/MAS 403 拉栓的SK/BT30/ SK/BT30 with pull stud DIN 69872/MAS 403
80.162.30.01	M12 螺紋的SK30/SK30 without pull stud with thread M12
80.162.40.01	M16 螺紋的SK40/SK40 without pull stud with thread M16
80.162.40.02	DIN 69872 拉栓的 SK40/SK40 with pull stud DIN 69872
80.162.40.04	ISO 7388-B 拉栓的 SK40/SK40 with pull stud ISO 7388-B
80.162.40.06	MAS 403 拉栓的 BT40/B T40 with pull stud MAS 403
80.162.T15	JBS R15-45 拉栓的 T1 5/ JBS T15 with pull stud JBS R15-45
80.163.25	HSK-25
80.163.32	HSK-32
80.163.40	HSK-40
80.163.50	HSK-50
80.163.63	HSK-63

## 支撐盤 / CHUCK SUPPORT

單刀桿用支撐盤

可適用於刀桿規格：SK30 - SK50,  
BT30 - BT50, HSK-25 - HSK-125,  
HAIMER Capto™ C3 - HAIMER Capto™ C8

Chuck support for single-chuck system.

Available in taper sizes SK30 – SK50,  
BT30 – BT50, HSK-25 – HSK-125,  
HAIMER Capto™ C3 – HAIMER Capto™ C8

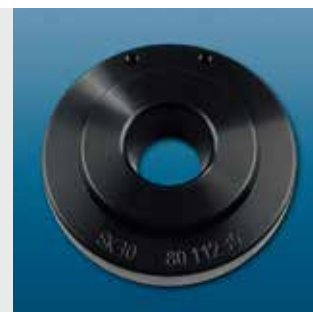

單支撐盤適用於 / Chuck support for

基本型 / 經濟型 / NG經濟型 / 專業經濟型 / NG專業經濟型 / Power Clamp Basic/Economic/Economic NG/Economic Plus/Economic Plus NG

訂購編號 / Order No.	錐度尺寸 / for taper size	訂購編號 / Order No.	錐度尺寸 / for taper size
80.112.30	SK/BT30	80.113.80	HSK-80
80.112.40	SK/BT40	80.113.10	HSK-100
80.112.45	SK/BT45	80.113.125	HSK-125
80.112.50	SK/BT50	80.114.30	HAIMER Capto™ C3
80.113.25	HSK-25	80.114.40	HAIMER Capto™ C4
80.113.32	HSK-32	80.114.50	HAIMER Capto™ C5
80.113.40	HSK-40	80.114.60	HAIMER Capto™ C6
80.113.50	HSK-50	80.114.80	HAIMER Capto™ C8
80.113.63	HSK-63		

精密支撐盤  
PRECISION CHUCK SUPPORT



精密支撐盤  
單刀桿用精密支撐盤

- 每一功能面都精密研磨
- 適用於刀桿錐度規格SK30 - SK50, HSK-25 - HSK-125, HAIMER Capto™ C6

Precision chuck support for single-chuck system.

- Fine machined functional surfaces

Available in taper sizes SK30 – SK50, HSK-25 – HSK-125, HAIMER Capto™ C6

精密支撐盤適用於 / Precision chuck support for  
NG刀具設定型 / 豪華型燒結機 / Power Clamp Preset NG / Power Clamp Premium

訂購編號 / Order No.	錐度尺寸 / for taper size
80.132.30	SK30
80.132.40	SK40
80.132.50	SK50
80.133.25	HSK-25
80.133.32	HSK-32
80.133.40	HSK-40

訂購編號 / Order No.	錐度尺寸 / for taper size
80.133.50	HSK-50
80.133.63	HSK-63
80.133.80	HSK-80
80.133.10	HSK-100
80.133.125	HSK-125
80.134.60	HAIMER Capto™ C6

豪華加強型燒結機用精密支撐盤  
PRECISION CHUCK SUPPORT FOR POWER CLAMP PREMIUM PLUS



豪華加強型燒結機用精密支撐盤

- 每一功能面都精密研磨
- 含刀桿保護銷
- 適用於刀桿錐度規格SK30 - SK50, BT30 - BT50, HSK-25 - HSK-125, HAIMER Capto™ C3 - HAIMER Capto™ C8

Precision chuck support for shrink fit machine Power Clamp Premium Plus.

- Fine machined functional surfaces
- With Pin for protection of the chuck

Available in taper sizes SK30 – SK50, BT30 – BT50, HSK-25 – HSK-125, HAIMER Capto™ C3 – HAIMER Capto™ C8

精密支撐盤適用於 / Precision chuck support for  
高階超級型燒結機 / Power Clamp Premium Plus

訂購編號 / Order No.	錐度尺寸 / for taper size
80.172.30	SK30
80.172.40	SK40
80.172.45	SK45
80.172.50	SK50
80.175.30	BT30
80.175.40	BT40
80.175.45	BT45
80.175.50	BT50
80.173.25	HSK-25
80.173.32	HSK-32
80.173.40	HSK-40

訂購編號 / Order No.	錐度尺寸 / for taper size
80.173.50	HSK-50
80.173.63	HSK-63
80.173.80	HSK-80
80.173.10	HSK-100
80.173.125	HSK-125
80.174.30	HAIMER Capto™ C3
80.174.40	HAIMER Capto™ C4
80.174.50	HAIMER Capto™ C5
80.174.60	HAIMER Capto™ C6
80.174.80	HAIMER Capto™ C8

## 旋轉支撐盤 CHUCK SUPPORT FOR ROTARY TABLE



### 旋轉支撐盤

適合錐度規格:SK30 - SK50, BT30 - BT50,  
HSK-25 - HSK-100, HAIMER Capto™ C3- HAIMER Capto™ C8

Chuck support for rotary table.

Available in taper sizes SK30 – SK50, BT30 – BT50,  
HSK-25 – HSK-100, HAIMER Capto™ C3 – HAIMER Capto™ C8

### 支撐盤適用於 / Chuck support for

高階專業型 / NG高階專業型 / 舒適型 / NG舒適型燒結機 / Power Clamp Profi Plus / Profi Plus NG / Comfort / Comfort NG

訂購編號 / Order No.	錐度尺寸 / for taper size
80.102.30	SK/BT30
80.102.40	SK/BT40
80.102.45	SK/BT45
80.102.50	SK/BT50
80.103.00	不同錐度尺寸 / various sizes
80.103.25	HSK-25
80.103.32	HSK-32
80.103.40	HSK-40
80.103.50	HSK-50
80.103.63	HSK-63
80.103.80	HSK-80
80.103.10	HSK-100
80.104.30	HAIMER Capto™ C3
80.104.40	HAIMER Capto™ C4
80.104.50	HAIMER Capto™ C5
80.104.60	HAIMER Capto™ C6
80.104.80	HAIMER Capto™ C8

ER 燒結刀桿用支撐盤  
CHUCK SUPPORT FOR ER SHRINK FIT COLLETS



ER 燒結刀桿用，含長度調整的支撐盤

- 高精度夾持
- 含快速可重現調整長度的止動銷
- 利用定位螺絲與螺母調整長度
- 整合在支撐盤上，節省空間
- 只需旋轉螺絲與螺帽，操作簡單
- 尤其適合於多軸車床，可重複調整多把刀具長度

Chuck support for ER shrink fit collets with integrated length presetting.

- Precise clamping of the collet
- Fast and repeatable length adjustment with stop pin
- Adjustment with set screw and counter nut
- Integrated in chuck support, thus very space-saving
- Easy handling by turning of set screw and counter nut
- Application suitable also at multi-spindle machines for repeatable length presetting of twin tools

支撐盤 / Chuck support	尺寸 / Size	訂購編號 / Order No.
ER11支撐盤/Chuck support for ER11	<b>ER11</b>	<b>80.135.11</b>
ER16支撐盤/Chuck support for ER16	<b>ER16</b>	<b>80.135.16</b>
ER20支撐盤/Chuck support for ER20	<b>ER20</b>	<b>80.135.20</b>
ER25支撐盤/Chuck support for ER25	<b>ER25</b>	<b>80.135.25</b>
ER32支撐盤/Chuck support for ER32	<b>ER32</b>	<b>80.135.32</b>
基本型 / 經濟型 / 新式專業經濟型燒結機用支撐座 / Base holder for Power Clamp Basic/Economic/Economic Plus		<b>80.155.00</b>



## 簡易型刀長設定裝置/EASY SET 簡易設定/SIMPLE PRESETTING

### 簡單設定刀長功能

- 快速簡單的調節刀具的擋板。
- 最大設定長度：150mm
- 精度：±0.05mm
- 適用於所有的燒結刀桿和燒結機（火焰，熱風，接觸式，感應式）
- 節省空間
- 性價比高
- 隨時可以導入使用
- 出貨時包含：止動片(Ø3-12, Ø12-20, Ø16-25 mm), 選購尺寸：Ø25-32 mm

### Simple presetting

- Quick and simple presetting of the protruding length of the tool
- Maximum protruding length: 150 mm
- Accuracy: ±0.05 mm
- Suitable for all shrink fit chucks and machines (flame, hot air, contact, induction)
- Space saving
- Excellent relationship between price and efficiency
- Can be added at any time
- Included in delivery: 3 stop clips (Ø 3-12, Ø 12-20, Ø 16-25 mm)
- Optional: Ø 25-32 mm



止動片/Stop clips

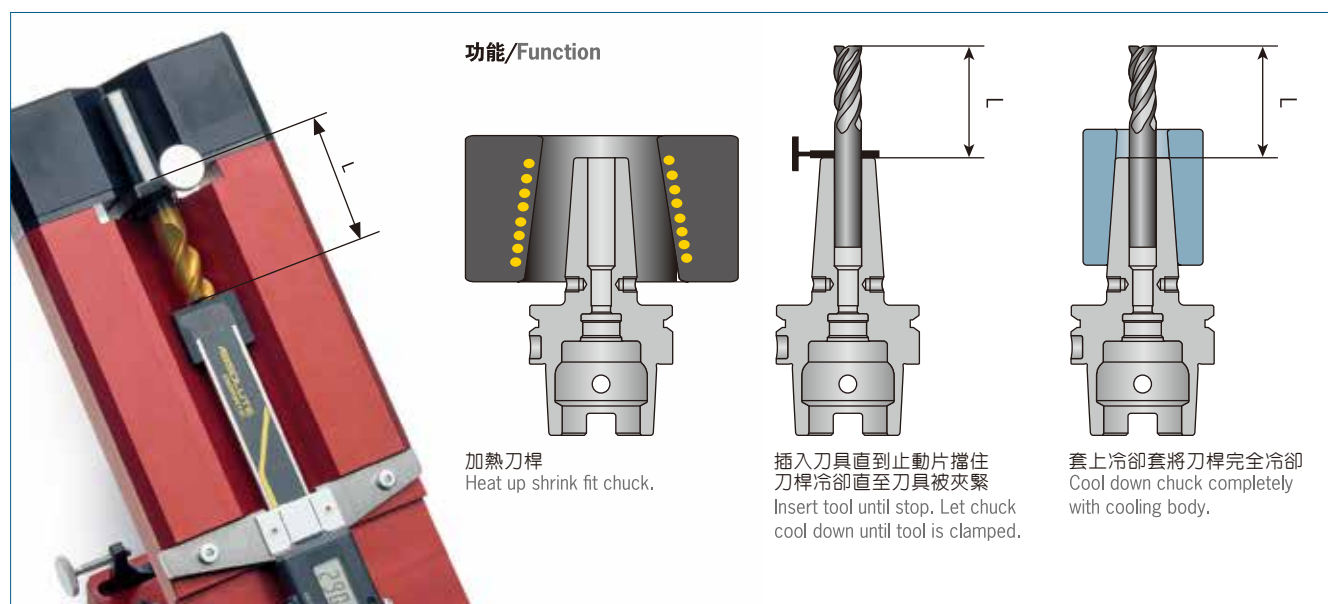

簡易型刀長設定裝置 / Easy Set	訂購編號 / Order No.
簡易型刀長設定裝置/Easy Set [mm]	可調長度 100 mm/100 mm protruding length <b>80.123.00</b>
簡易型刀長設定裝置/Easy Set [mm]	可調長度 150mm/150 mm protruding length <b>80.125.00</b>
止動片/Stop clip	夾持柄徑 Ø3-12 mm/for clamping Ø3-12 mm <b>80.123.01</b>
止動片/Stop clip	夾持柄徑 Ø12-20 mm/for clamping Ø12-20 mm <b>80.123.02</b>
止動片/Stop clip	夾持柄徑 Ø16-25 mm/for clamping Ø16-25 mm <b>80.123.03</b>
止動片/Stop clip	夾持柄徑 Ø25-32 mm/for clamping Ø25-32 mm <b>80.123.04</b>

快速長度設定裝置/QUICK SET  
長度設定/LENGTH PRESETTING

適用於沒有刀長設定螺絲的燒結刀桿 (例如：迷你型刀桿) 的刀具刀長設定

- 利用止動桿可以重複而快速的調整刀具長度
- 利用止動螺絲與鎖緊螺母調整
- 與支撐盤整合成在一起，節省空間
- 操作方便，只需調節螺絲與螺帽
- 特別適用於多主軸工具機，可重複設定多把刀具的長度。



圖片顯示：快速測量裝置與支撐座  
搭配使用 (出貨不含支撐座)  
Picture shows: Quick Set with base  
holder (Base holder not included in  
delivery)

**Length adjustment for shrink fit chucks without back-up screw, e. g. Mini Shrink**

- Fast, repeatable length adjustment of the total tool assembly with stop pin
- Adjustment with set screw and counter nut
- Integrated in chuck support, thus very space-saving
- Easy handling by turning of set screw and counter nut
- Application suitable also at multi-spindle machines for repeatable length presetting of twin tools



快速型刀長設定裝置 / Quick Set	尺寸 / Size	訂購編號 / Order No.
快速長度設定裝置/LengthPresetting Quick Set for	SK/BT40	80.136.240
快速長度設定裝置/LengthPresetting Quick Set for	HSK-E25	80.136.325
快速長度設定裝置/LengthPresetting Quick Set for	HSK-E32	80.136.332
快速長度設定裝置/LengthPresetting Quick Set for	HSK-E40	80.136.340
快速長度設定裝置/LengthPresetting Quick Set for	HSK-E50	80.136.350
快速長度設定裝置/LengthPresetting Quick Set for	HSK-A63	80.136.363
快速長度設定裝置/LengthPresetting Quick Set for	CAPTO C5	80.136.450
基本型 / 經濟型 / 新式專業經濟型燒結機用支撐座 / Base holder for Power Clamp Basic/Economic/Economic Plus		80.155.00

# 冷卻轉換套與冷卻轉換套毛胚 COOLING ADAPTER AND COOLING ADAPTER BLANKS



用冷卻轉換套，所有形狀的燒結刀桿都能被冷卻。轉換套插入冷卻套內並卡緊，一起放置在燒結刀桿上。

– 使用於為Ø14-16mm與Ø25-32mm冷卻套上這兩個冷卻套上有卡緊裝置。

By using cooling adapters all forms of shrink fit chucks can be cooled. The adapter is inserted into the cooling body and locked. Then it can be placed onto the shrink fit chuck.

– Cooling bodies for Ø 14–16 mm and Ø 25–32 mm with side lock

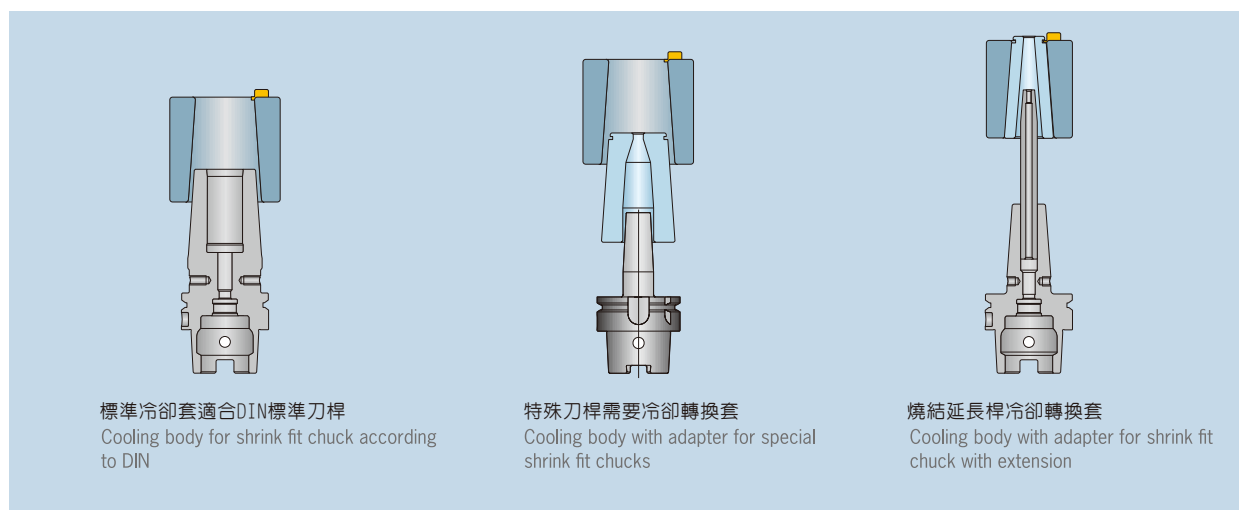

標準冷卻套適合DIN標準刀桿  
Cooling body for shrink fit chuck according to DIN

特殊刀桿需要冷卻轉換套  
Cooling body with adapter for special shrink fit chucks

燒結延長桿冷卻轉換套  
Cooling body with adapter for shrink fit chuck with extension

冷卻轉換套毛胚  
客戶自行加工，適合任何形狀的燒結刀桿

### Cooling adapter blanks

For individual adaption to each shrink fit chuck by the user.

適用於Ø25-32mm  
冷卻套  
For Cooling body:  
Ø 25–32 mm

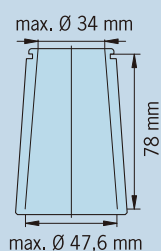

適用於Ø14-16mm  
冷卻套  
For Cooling body:  
Ø 14–16 mm

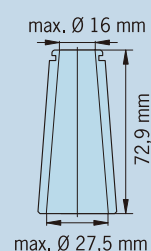

附件 / Accessories	訂購編號 / Order No.
Ø14-16 mm 冷卻套的轉換套毛胚 / Cooling adapter blanks for cooling body Ø14-16 mm	80.105.14.0
Ø25-32 mm 冷卻套的轉換套毛胚 / Cooling adapter blanks for cooling body Ø25-32 mm	80.105.16.0
Ø12 mm/Ø16 mm 冷卻轉換套 / Cooling adapter for extensions Ø12 mm/Ø16 mm	80.105.14.1.1
Ø20 mm 冷卻轉換套 / Cooling adapter for extensions Ø20 mm	80.105.14.1.2
Ø3-5mm 冷卻轉換套 / Coolingadapter for shrink fit chucks Ø3-5 mm	80.105.14.1.3
冷卻轉換套 80.105.19.1 Ø16mm 重量型刀桿使用 / Cooling adapter Heavy Duty Ø16 mm for cooling body 80.105.19.1	80.105.19.3.1
搭配冷卻套 80.105.19.1 Ø20mm 重量型刀桿使用 / Cooling adapter Heavy Duty Ø20 mm for cooling body 80.105.19.1	80.105.19.3.2
搭配冷卻套 80.105.19.1 Ø25mm 重量型刀桿使用 / Cooling adapter Heavy Duty Ø25 mm for cooling body 80.105.19.1	80.105.19.3.3
搭配冷卻套 80.105.19.1 Ø32mm 重量型刀桿使用 / Cooling adapter Heavy Duty Ø32 mm for cooling body 80.105.19.1	80.105.19.3.4
冷卻轉換套底座 / Base for cooling adapters	80.105.14.1.99

迷你型燒結機用加熱冷卻套  
MINI SHRINK SHRINK AND COOLING SLEEVES

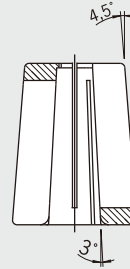

- 迷你型燒結刀桿冷卻套
- 防止迷你型燒結刀桿過熱
  - 延緩刀桿使用壽命
  - 方便安全的操作
  - 與Ø6-8mm標準冷卻套配合使用

- For shrinking and cooling of Mini Shrink chucks.
- Protect Mini Shrink chucks from overheating
  - Extend lifetime of shrink fit chucks
  - Secure and user friendly handling
  - Cooling with standard cooling body Ø 6 – 8 mm

加裝於刀桿上  
使用安裝冷卻套

Heat up  
With shrink and cooling sleeve

先將迷你冷卻套，插入在冷卻套內冷卻

Cool down  
With shrink and cooling sleeve and cooling body

迷你刀桿冷卻套 / Fitting sleeves for Mini Shrink chucks							訂購編號 / Order No.	
超細刀桿 / Extra slim								
尺寸 / Size(mm)	Ø03	Ø04	Ø05	Ø06	Ø08	Ø10	Ø12	
訂購編號 / Order No. 80.105.14...	...2.01	...2.02	...2.03	...2.04	...2.05	...2.06	...2.07	
標準 / Standard								
尺寸 / Size(mm)	Ø03	Ø04	Ø05	Ø06	Ø08	Ø10	Ø12	Ø16
訂購編號 / Order No. 80.105.14...	...2.04	...2.08	...2.05	...2.09	...2.10	...2.11	...2.12	...2.16
整理盤 / Base							80.105.14.2.99	
整理盤含冷卻套套組 (12件) / Set with base(12 pcs)							80.105.14.2.00	

## 溫控裝置的冷卻系統

### TME COOLING SYSTEM WITH TEMPERATURE CONTROL

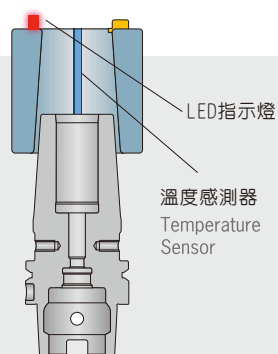

為了安全操作，燒結刀桿整個冷卻過程中均有溫度控制

- 鋁合金本體內的溫度感測器測量溫度
- 冷卻中：紅燈
- 冷卻結束：綠燈
- 大大的降低了被燙傷的危險
- 專利的溫度控制功能

Temperature control of the shrink fit chuck during the cooling process for a safe handling

- Sensor in aluminium body measures temperature.
- If temperature is too high: red light
- If temperature is at right level: green light
- Minimizing danger of injury due to hot chucks
- Patented temperature control

訂購編號 / Order No.

13 kW燒結機用TME溫度控制智慧型冷卻機/TMEIntelligent Cooling System for 13kW machines

**80.105.19.00**

20 kW燒結機用TME溫度控制智慧型冷卻機/TMEIntelligent Cooling System for 20kW machines

**80.105.19.10**

燒結刀桿長度調整用支撐彈簧

TENSION SPRINGS FOR LENGTH PRESETTING FOR SHRINK FIT CHUCKS



- 放置在刀桿夾持孔內
- 刀具被彈簧支撐到止動位置
- 刀桿內支撐螺絲可保留
- 適合於所有型式的燒結刀桿

- Spring is set into clamping bore
- Spring presses tool against stop disc
- Backup screw can remain in chuck
- Fits all common shrink fit chucks



長度調整用支撐彈簧  
Tension spring for length presetting

	訂購編號 / Order No.									
支撐彈簧 / Tension spring	Ø 6	Ø 8	Ø 10	Ø 12	Ø 14	Ø 16	Ø 18	Ø 20	Ø 25	Ø 32
訂單編號 / Order No. 85.830...	...06	...08	...10	...12	...14	...16	...18	...20	...25	...32
支撐彈簧套組 (每個尺寸的彈簧有10個) / Tension spring set (10 pcs. of each size) incl. grab										85.830.00

## 斷刀取出裝置 SHRINK-OUT DEVICE



### 斷刀取出裝置

- 一套裝含1個底座與6根頂桿（3種直徑各有兩種長度），不含鉗子
- 橡膠底座保護刀桿
- 連同托盤可放入儲物盒
- 適用於所有的燒結機

### Shrink-out device for broken tools.

- Set with 1 base plate and 6 pins (3 diameters in 2 lengths each), without pliers
- Rubber plate for saving the chuck
- With drawer insert for craning box
- Suitable for all Power Clamp shrink fit machines

	訂購編號 / Order No.
斷刀取出裝置 / Shrink-out device	80.126.00
鉗子 / Combination pliers	80.107.00

附件 / Accessories	訂購編號 / Order No.
頂桿 / Pin 160 mm x 2.3 mm	113027-0004
頂桿 / Pin 160 mm x 4.7 mm	113027-0005
頂桿 / Pin 160 mm x 5.5 mm	911001-0002
頂桿 / Pin 275 mm x 2.3 mm	113027-0007
頂桿 / Pin 275 mm x 4.7 mm	113027-0008
頂桿 / Pin 275 mm x 5.5 mm	911001-0003

燒結刀桿用清潔毛刷 / SHRINK FIT BRUSH  
 燒結刀桿用減徑筒夾 / REDUCTION SLEEVES FOR SHRINK FIT CHUCKS

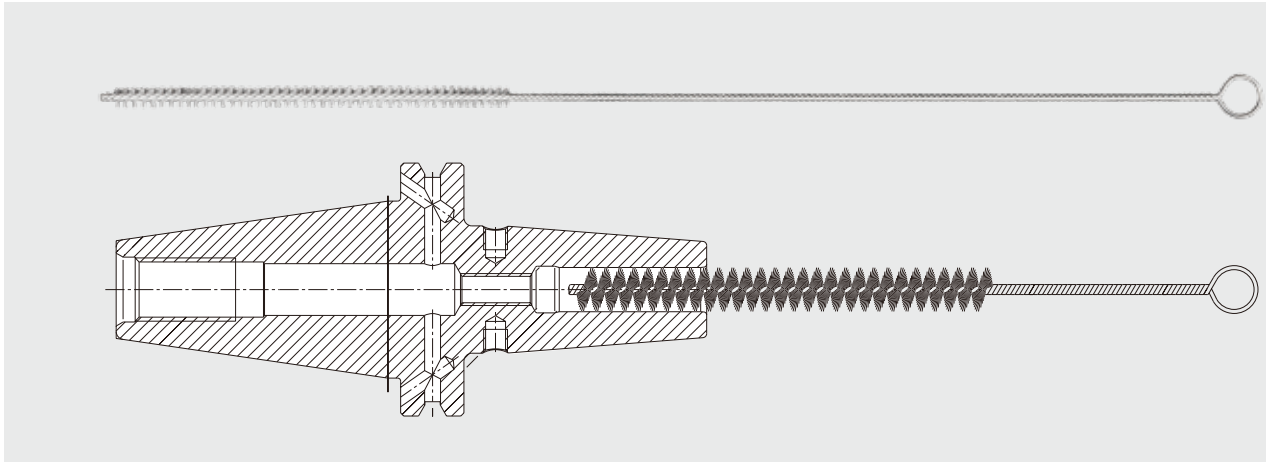

為了達到最好的燒結夾緊，必須定期清理刀桿內部，使刀桿內部維持在無油的狀態，可以使用清潔溶劑（例如剎車清潔劑）。清潔刷專門針對刀桿設計，方便，快捷，有效的清潔刀桿內部，從而使刀桿一直維持高精度的工作狀態下。

In order to achieve the best possible shrink fit connection, a grease free socket and shank is necessary. The cleaning can be done by a cold solvent (e.g. brake cleaner). An appropriate cleaning brush is necessary to clean the socket of the Shrink Fit Chuck.

清潔毛刷 / Shrink Fit Brush	Ø [mm]
訂單編號 / Order No. 86.200.01	3
86.200.02	3.5
86.200.02	4
86.200.02	4.5
86.200.02	5
86.200.03	6
86.200.03	8

清潔毛刷 / Shrink Fit Brush	Ø [mm]
訂單編號 / Order No. 86.200.04	10
86.200.04	12
86.200.06	14
86.200.06	16
86.200.07	18
86.200.07	20
86.200.08	25

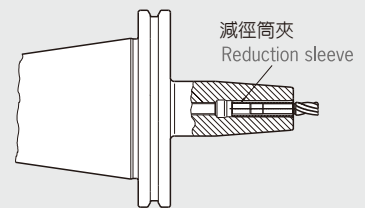
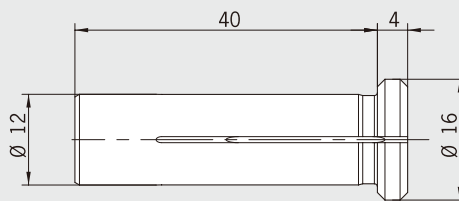

用途：  
用於內孔為 Ø12 mm 的燒結刀桿來夾持小柄徑刀具

Use:  
For clamping small shanks in chucks with 12 mm ID's.

第一步：先把減徑筒夾燒結入刀桿中  
 第二步：再把刀具夾入減徑筒夾中

First step: shrink sleeve into bore of chuck.  
 Second step: clamp tool shank in reduction sleeve.

– 適用於柄徑公差h6範圍的刀具

– Shank tolerance h6

訂單編號 / Order No	夾持範圍 / Clamping Ø D [mm]
79.150.03	3
79.150.04	4
79.150.06	6



## 廢氣吸收裝置 AUXILIARY FUME EXTRACTION UNIT



廢氣吸收裝置用來吸收和過濾加熱過程中產生的氣體。

Auxiliary fume extraction unit to remove and filter vapours, which are produced during the shrink process.

廢氣吸收裝置 / Auxiliary fume extraction unit 線圈 / for coil	燒結機機型 / Shrink fit machine	訂購編號 / Order No.
VS32-H/M	NG高階專業型 / NG高階舒適型 / NG高階新式舒適型 / NG刀具設定型 <b>Profi Plus NG/Comfort (NG)/Comfort Plus (NG)/Preset NG</b>	<b>80.101.02NG.01</b>
VS32-H	NG豪華型 / 高階超級型 / <b>Power Clamp Premium (NG)/Premium Plus</b>	<b>80.101.02NG.02</b>
VS32-M	高階超級型 / <b>Power Clamp Premium Plus</b>	<b>80.101.03NG.02</b>
V2008	經濟型 / 專業經濟型 / 舒適型 <b>Power Clamp Economic/Economic Plus/Comfort</b>	<b>80.151.00.01</b>
13 kW HD/20 kW	NG專業經濟型 / NG舒適型 / NG刀具設定型 <b>Power Clamp Economic Plus NG/Comfort NG/Preset NG</b>	<b>80.151.10.01</b>

## 13 KW HD 升級線圈 UPGRADE KIT 13 KW HD COIL



### 用途：

適用於直徑 $\varnothing 50$  mm 的重型燒結刀桿

### 出貨時包含：

- 13kw HD線圈
- 線圈底座
- 定位環組
- 最新的軟體
- $\varnothing 40-50$  mm 的HD冷卻套
- 冷卻管套裝
- 冷卻管接頭
- 選購：冷卻轉換套

僅適用於2012年1月以後生產的經濟加強型燒結機(NG), 舒適型(NG)和刀長設定型(NG)

### Use:

For shrinking of Heavy Duty Shrink Chucks up to  $\varnothing 50$  mm.

### Delivery includes:

- 13 kW HD coil
- Coil base
- Set of stop discs
- Latest software
- HD cooling body  $\varnothing 40-50$  mm
- hose set for HD cooling body
- Coolant Manifold Connection
- Optional: cooling adapter for HD cooling body

Upgrade only possible for existing shrink fit machine Power Clamp Economic Plus (NG), Comfort (NG) or Preset (NG) that were produced after 01/2012.

訂購編號 /Order No.

13 kW HD線圈升級組合 / Upgrade Kit 13 kW HD coil

**80.151.30.10**

## 定位環 STOP DISCS



用途：  
多種定位環將加熱線圈準確定位在刀桿上

Use:  
Changeable stop discs for positioning the coil above the chuck.

定位環 / Stop discs	夾持範圍 / Clamping Ø D [mm]	
<b>N29線圈用(NANO繞結機)/ for coil N29 (Power Clamp Nano)</b>		
訂購編號/Order No. <b>80.162.03</b>	3 – 5 mm	
<b>80.162.06</b>	6 – 8 mm	
<b>80.162.10.2</b>	10 – 16 mm	
<b>80.162.10</b>	10 – 12 mm	N29 線圈用定位環套裝組 / Stop disc set N29
<b>80.162.00</b>		
<b>13kW V2008線圈用/ for 13 kW coil V2008</b>		
訂購編號/Order No. <b>80.152.03</b>	3 – 5 mm	
<b>80.152.06</b>	6 – 12 mm	
<b>80.152.14</b>	14 – 16 mm	
<b>80.152.18</b>	18 – 20 mm	
<b>80.152.25</b>	25 – 32 mm	
<b>80.152.00</b>		13 kWV2008 線圈用定位環套裝組/Set of stop discs 13 kW V2008
<b>80.152.03.1</b>	3 – 5 mm	分裂式定位環/Stopdisc splitted
<b>80.152.06.1</b>	6 – 12 mm	分裂式定位環/Stopdisc splitted
<b>80.152.14.1</b>	14 – 16 mm	分裂式定位環/Stopdisc splitted
<b>80.152.18.1</b>	18 – 20 mm	分裂式定位環/Stopdisc splitted
<b>80.152.25.1</b>	25 – 32 mm	分裂式定位環/Stopdisc splitted
<b>80.152.00.1</b>		13 kWV2008 線圈用定位環套裝組(分裂式)/ Set of stop discs 13 kW V2008 (splitted)
<b>80.152.06.2</b>	6 – 12 mm	超短型刀柄用定位環/ Stop disc for ultra short Power Shrink Chucks
<b>80.152.14.2</b>	14 – 20 mm	超短型刀柄用定位環/ Stop disc for ultra short Power Shrink Chucks
<b>80.152.25.2</b>	25 – 32 mm	超短型刀柄用定位環/ Stop disc for ultra short Power Shrink Chucks
<b>20kW和13kW HD線圈用/ for 20 kW coil and 13 kW HD coil</b>		
訂購編號/Order No. <b>80.151.10.42</b>	16 – 20 mm	
<b>80.151.10.41</b>	20 – 32 mm	
<b>80.151.40.40</b>	40 – 50 mm	
<b>80.151.10.42.1</b>	16 – 20 mm	20kW/13kW HD分裂式定位環/ Stop disc 20 kW/13 kW splitted
<b>80.151.10.41.1</b>	25 – 32 mm	20kW/13kW HD分裂式定位環/ Stop disc 20 kW/13 kW splitted
<b>80.151.40.40.1</b>	40 – 50 mm	20kW/13kW HD分裂式定位環/ Stop disc 20 kW/13 kW splitted

**HAIMER®**  
Quality Wins.



CNC刀具系列  
Tooling Technology



刀桿燒結機  
Shrinking Technology



刀桿動平衡機  
Balancing Technology



3D-Taster  
Measuring Instruments



刀具管理系統  
Tool Management



**JIMMOR**  
竣貿國際股份有限公司



總公司：40252台中市南區復興路二段120-2號  
TEL：04-2260-5352 FAX：04-2260-8765  
北部營業處：33548桃園市大溪區埔頂路一段406號  
TEL：03-380-8216 FAX：03-380-3362  
<http://www.jimmore.com.tw>  
E-mail:sales@jimmore.com.tw